

# CD4066B CMOS QUAD BILATERAL SWITCH

SCHS051D – NOVEMBER 1998 – REVISED SEPTEMBER 2003

- 15-V Digital or  $\pm 7.5$ -V Peak-to-Peak Switching
- 125- $\Omega$  Typical On-State Resistance for 15-V Operation
- Switch On-State Resistance Matched to Within 5  $\Omega$  Over 15-V Signal-Input Range
- On-State Resistance Flat Over Full Peak-to-Peak Signal Range
- High On/Off Output-Voltage Ratio: 80 dB Typical at  $f_{IS} = 10$  kHz,  $R_L = 1$  k $\Omega$
- High Degree of Linearity: <0.5% Distortion Typical at  $f_{IS} = 1$  kHz,  $V_{IS} = 5$  V p-p,  $V_{DD} - V_{SS} \geq 10$  V,  $R_L = 10$  k $\Omega$
- Extremely Low Off-State Switch Leakage, Resulting in Very Low Offset Current and High Effective Off-State Resistance: 10 pA Typical at  $V_{DD} - V_{SS} = 10$  V,  $T_A = 25^\circ\text{C}$
- Extremely High Control Input Impedance (Control Circuit Isolated From Signal Circuit): 10<sup>12</sup>  $\Omega$  Typical
- Low Crosstalk Between Switches: -50 dB Typical at  $f_{IS} = 8$  MHz,  $R_L = 1$  k $\Omega$
- Matched Control-Input to Signal-Output Capacitance: Reduces Output Signal Transients
- Frequency Response, Switch On = 40 MHz Typical
- 100% Tested for Quiescent Current at 20 V
- 5-V, 10-V, and 15-V Parametric Ratings
- Meets All Requirements of JEDEC Tentative Standard No. 13-B, *Standard Specifications for Description of "B" Series CMOS Devices*
- Applications:
  - Analog Signal Switching/Multiplexing: Signal Gating, Modulator, Squelch Control, Demodulator, Chopper, Commutating Switch
  - Digital Signal Switching/Multiplexing
  - Transmission-Gate Logic Implementation
  - Analog-to-Digital and Digital-to-Analog Conversion
  - Digital Control of Frequency, Impedance, Phase, and Analog-Signal Gain

E, F, M, NS, OR PW PACKAGE  
(TOP VIEW)

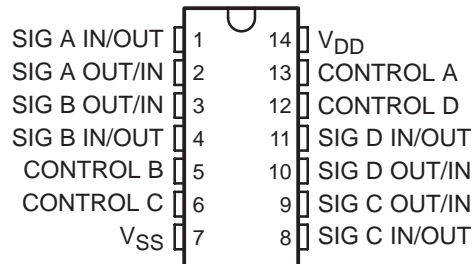

## description/ordering information

The CD4066B is a quad bilateral switch intended for the transmission or multiplexing of analog or digital signals. It is pin-for-pin compatible with the CD4016B, but exhibits a much lower on-state resistance. In addition, the on-state resistance is relatively constant over the full signal-input range.

The CD4066B consists of four bilateral switches, each with independent controls. Both the p and the n devices in a given switch are biased on or off simultaneously by the control signal. As shown in Figure 1, the well of the n-channel device on each switch is tied to either the input (when the switch is on) or to  $V_{SS}$  (when the switch is off). This configuration eliminates the variation of the switch-transistor threshold voltage with input signal and, thus, keeps the on-state resistance low over the full operating-signal range.

The advantages over single-channel switches include peak input-signal voltage swings equal to the full supply voltage and more constant on-state impedance over the input-signal range. However, for sample-and-hold applications, the CD4016B is recommended.



Please be aware that an important notice concerning availability, standard warranty, and use in critical applications of Texas Instruments semiconductor products and disclaimers thereto appears at the end of this data sheet.

PRODUCTION DATA information is current as of publication date. Products conform to specifications per the terms of Texas Instruments standard warranty. Production processing does not necessarily include testing of all parameters.

 **TEXAS  
INSTRUMENTS**

POST OFFICE BOX 655303 • DALLAS, TEXAS 75265

Copyright © 2003, Texas Instruments Incorporated

# CD4066B CMOS QUAD BILATERAL SWITCH

SCHS051D – NOVEMBER 1998 – REVISED SEPTEMBER 2003

## description/ordering information (continued)

### ORDERING INFORMATION

TA	PACKAGE†		ORDERABLE PART NUMBER	TOP-SIDE MARKING
-55°C to 125°C	CDIP – F	Tube of 25	CD4066BF3A	CD4066BF3A
	PDIP – E	Tube of 25	CD4066BE	CD4066BE
	SOIC – M	Tube of 50	CD4066BM	CD4066BM
		Reel of 2500	CD4066BM96	
		Reel of 250	CD4066BMT	
	SOP – NS	Reel of 2000	CD4066BNSR	CD4066B
	TSSOP – PW	Tube of 90	CD4066BPW	CM066B
Reel of 2000		CD4066BPWR		

† Package drawings, standard packing quantities, thermal data, symbolization, and PCB design guidelines are available at [www.ti.com/sc/package](http://www.ti.com/sc/package).

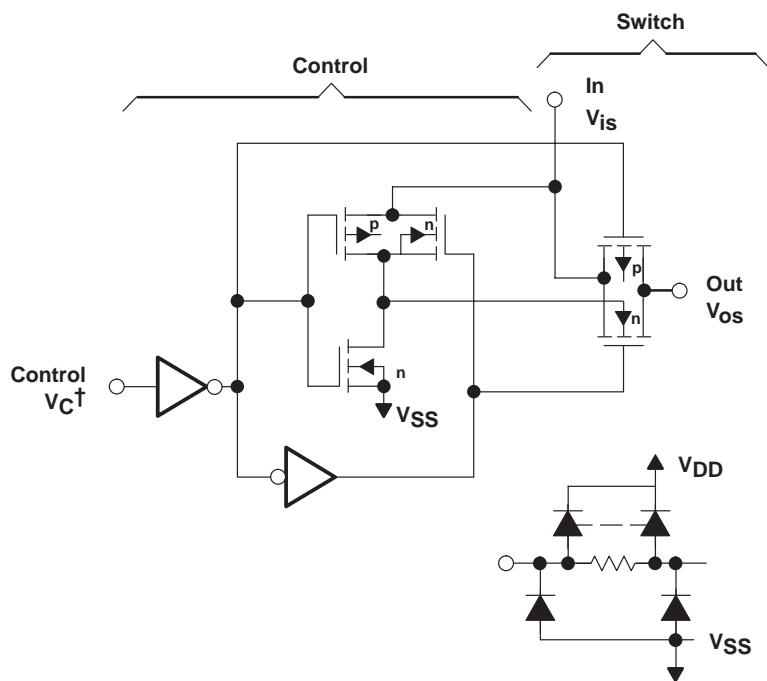

† All control inputs are protected by the CMOS protection network.

NOTES: A. All p substrates are connected to  $V_{DD}$ .

B. Normal operation control-line biasing: switch on (logic 1),  $V_C = V_{DD}$ ; switch off (logic 0),  $V_C = V_{SS}$

C. Signal-level range:  $V_{SS} \leq V_{is} \leq V_{DD}$

92CS-29113

Figure 1. Schematic Diagram of One-of-Four Identical Switches and Associated Control Circuitry

# CD4066B CMOS QUAD BILATERAL SWITCH

SCHS051D – NOVEMBER 1998 – REVISED SEPTEMBER 2003

## absolute maximum ratings over operating free-air temperature (unless otherwise noted)<sup>†</sup>

DC supply-voltage range, $V_{DD}$ (voltages referenced to $V_{SS}$ terminal)	–0.5 V to 20 V
Input voltage range, $V_{is}$ (all inputs)	–0.5 V to $V_{DD} + 0.5$ V
DC input current, $I_{IN}$ (any one input)	±10 mA
Package thermal impedance, $\theta_{JA}$ (see Note 1): E package	80°C/W
M package	86°C/W
NS package	76°C/W
PW package	113°C/W
Lead temperature (during soldering):	
At distance $1/16 \pm 1/32$ inch ( $1,59 \pm 0,79$ mm) from case for 10 s max	265°C
Storage temperature range, $T_{stg}$	–65°C to 150°C

<sup>†</sup> Stresses beyond those listed under “absolute maximum ratings” may cause permanent damage to the device. These are stress ratings only, and functional operation of the device at these or any other conditions beyond those indicated under “recommended operating conditions” is not implied. Exposure to absolute-maximum-rated conditions for extended periods may affect device reliability.

NOTE 1: The package thermal impedance is calculated in accordance with JESD 51-7.

## recommended operating conditions

	MIN	MAX	UNIT
$V_{DD}$ Supply voltage	3	18	V
$T_A$ Operating free-air temperature	–55	125	°C

# CD4066B

## CMOS QUAD BILATERAL SWITCH

SCHS051D – NOVEMBER 1998 – REVISED SEPTEMBER 2003

### electrical characteristics

PARAMETER	TEST CONDITIONS	LIMITS AT INDICATED TEMPERATURES								UNIT
		V <sub>IN</sub> (V)	V <sub>DD</sub> (V)	-55°C	-40°C	85°C	125°C	25°C		
								TYP	MAX	
I <sub>DD</sub> Quiescent device current		0, 5	5	0.25	0.25	7.5	7.5	0.01	0.25	μA
		0, 10	10	0.5	0.5	15	15	0.01	0.5	
		0, 15	15	1	1	30	30	0.01	1	
		0, 20	20	5	5	150	150	0.02	5	
<b>Signal Inputs (V<sub>IS</sub>) and Outputs (V<sub>OS</sub>)</b>										
r <sub>on</sub> On-state resistance (max)	V <sub>C</sub> = V <sub>DD</sub> , R <sub>L</sub> = 10 kΩ returned to $\frac{(V_{DD} - V_{SS})}{2}$ , V <sub>IS</sub> = V <sub>SS</sub> to V <sub>DD</sub>	5		800	850	1200	1300	470	1050	Ω
		10		310	330	500	550	180	400	
		15		200	210	300	320	125	240	
Δr <sub>on</sub> On-state resistance difference between any two switches	R <sub>L</sub> = 10 kΩ, V <sub>C</sub> = V <sub>DD</sub>	5						15		Ω
		10						10		
		15						5		
THD Total harmonic distortion	V <sub>C</sub> = V <sub>DD</sub> = 5 V, V <sub>SS</sub> = -5 V, V <sub>IS(p-p)</sub> = 5 V (sine wave centered on 0 V), R <sub>L</sub> = 10 kΩ, f <sub>IS</sub> = 1-kHz sine wave							0.4		%
-3-dB cutoff frequency (switch on)	V <sub>C</sub> = V <sub>DD</sub> = 5 V, V <sub>SS</sub> = -5 V, V <sub>IS(p-p)</sub> = 5 V (sine wave centered on 0 V), R <sub>L</sub> = 1 kΩ							40		MHz
-50-dB feedthrough frequency (switch off)	V <sub>C</sub> = V <sub>SS</sub> = -5 V, V <sub>IS(p-p)</sub> = 5 V (sine wave centered on 0 V), R <sub>L</sub> = 1 kΩ							1		MHz
I <sub>IS</sub> Input/output leakage current (switch off) (max)	V <sub>C</sub> = 0 V, V <sub>IS</sub> = 18 V, V <sub>OS</sub> = 0 V; and V <sub>C</sub> = 0 V, V <sub>IS</sub> = 0 V, V <sub>OS</sub> = 18 V	18		±0.1	±0.1	±1	±1	±10 <sup>-5</sup>	±0.1	μA
-50-dB crosstalk frequency	V <sub>C(A)</sub> = V <sub>DD</sub> = 5 V, V <sub>C(B)</sub> = V <sub>SS</sub> = -5 V, V <sub>IS(A)</sub> = 5 V <sub>p-p</sub> , 50-Ω source, R <sub>L</sub> = 1 kΩ							8		MHz
t <sub>pd</sub> Propagation delay (signal input to signal output)	R <sub>L</sub> = 200 kΩ, V <sub>C</sub> = V <sub>DD</sub> , V <sub>SS</sub> = GND, C <sub>L</sub> = 50 pF, V <sub>IS</sub> = 10 V (square wave centered on 5 V), t <sub>r</sub> , t <sub>f</sub> = 20 ns	5						20	40	ns
		10						10	20	
		15						7	15	
C <sub>IS</sub> Input capacitance	V <sub>DD</sub> = 5 V, V <sub>C</sub> = V <sub>SS</sub> = -5 V							8		pF
C <sub>OS</sub> Output capacitance	V <sub>DD</sub> = 5 V, V <sub>C</sub> = V <sub>SS</sub> = -5 V							8		pF
C <sub>IOS</sub> Feedthrough	V <sub>DD</sub> = 5 V, V <sub>C</sub> = V <sub>SS</sub> = -5 V							0.5		pF



**electrical characteristics (continued)**

CHARACTERISTIC	TEST CONDITIONS	LIMITS AT INDICATED TEMPERATURES						UNIT	
		V <sub>DD</sub> (V)	-55°C	-40°C	85°C	125°C	25°C		
							TYP	MAX	
<b>Control (V<sub>C</sub>)</b>									
V <sub>ILC</sub> Control input, low voltage (max)	I <sub>is</sub>   < 10 μA, V <sub>is</sub> = V <sub>SS</sub> , V <sub>OS</sub> = V <sub>DD</sub> , and V <sub>is</sub> = V <sub>DD</sub> , V <sub>OS</sub> = V <sub>SS</sub>	5	1	1	1	1	1	1	V
		10	2	2	2	2	2	2	
		15	2	2	2	2	2	2	
V <sub>IHC</sub> Control input, high voltage	See Figure 6	5	3.5 (MIN)						V
		10	7 (MIN)						
		15	11 (MIN)						
I <sub>IN</sub> Input current (max)	V <sub>is</sub> ≤ V <sub>DD</sub> , V <sub>DD</sub> - V <sub>SS</sub> = 18 V, V <sub>CC</sub> ≤ V <sub>DD</sub> - V <sub>SS</sub>	18	±0.1	±0.1	±1	±1	±10 <sup>-5</sup>	±0.1	μA
Crosstalk (control input to signal output)	V <sub>C</sub> = 10 V (square wave), t <sub>r</sub> , t <sub>f</sub> = 20 ns, R <sub>L</sub> = 10 kΩ	10					50		mV
Turn-on and turn-off propagation delay	V <sub>IN</sub> = V <sub>DD</sub> , t <sub>r</sub> , t <sub>f</sub> = 20 ns, C <sub>L</sub> = 50 pF, R <sub>L</sub> = 1 kΩ	5					35	70	ns
		10					20	40	
		15					15	30	
Maximum control input repetition rate	V <sub>is</sub> = V <sub>DD</sub> , V <sub>SS</sub> = GND, R <sub>L</sub> = 1 kΩ to GND, C <sub>L</sub> = 50 pF, V <sub>C</sub> = 10 V (square wave centered on 5 V), t <sub>r</sub> , t <sub>f</sub> = 20 ns, V <sub>OS</sub> = 1/2 V <sub>OS</sub> at 1 kHz	5					6		MHz
		10					9		
		15					9.5		
C <sub>I</sub> Input capacitance							5	7.5	pF

**switching characteristics**

V <sub>DD</sub> (V)	SWITCH INPUT						SWITCH OUTPUT, V <sub>OS</sub> (V)	
	V <sub>is</sub> (V)	I <sub>is</sub> (mA)					MIN	MAX
		-55°C	-40°C	25°C	85°C	125°C		
5	0	0.64	0.61	0.51	0.42	0.36	0.4	
5	5	-0.64	-0.61	-0.51	-0.42	-0.36	4.6	
10	0	1.6	1.5	1.3	1.1	0.9	0.5	
10	10	-1.6	-1.5	-1.3	-1.1	-0.9	9.5	
15	0	4.2	4	3.4	2.8	2.4	1.5	
15	15	-4.2	-4	-3.4	-2.8	-2.4	13.5	

# CD4066B CMOS QUAD BILATERAL SWITCH

SCHS051D – NOVEMBER 1998 – REVISED SEPTEMBER 2003

## TYPICAL CHARACTERISTICS

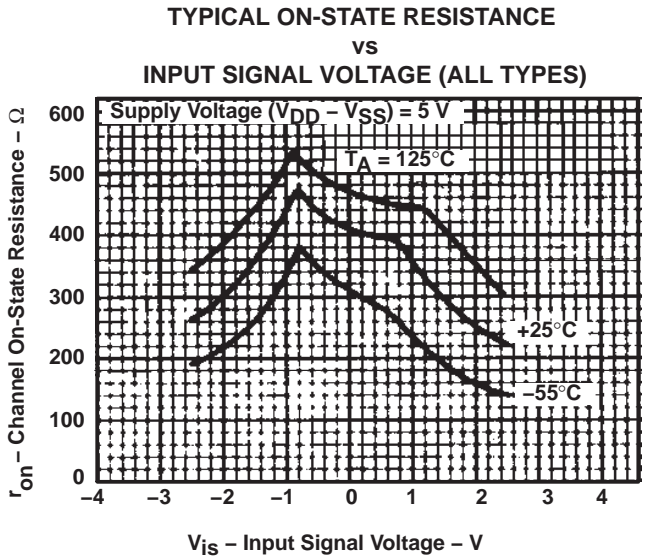

92CS-27326RI

Figure 2

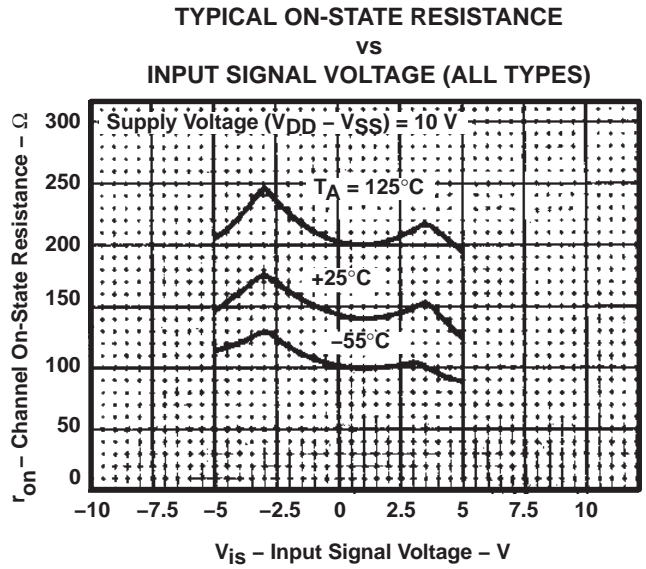

92CS-27327RI

Figure 3

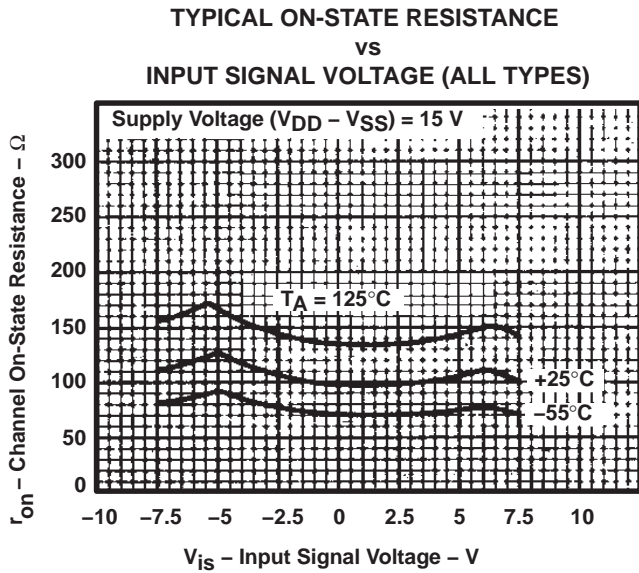

92CS-27329RI

Figure 4

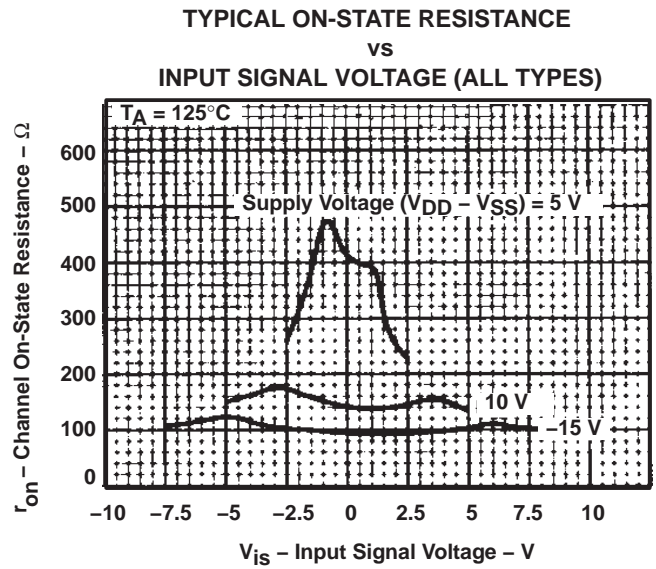

92CS-27330RI

Figure 5

TYPICAL CHARACTERISTICS

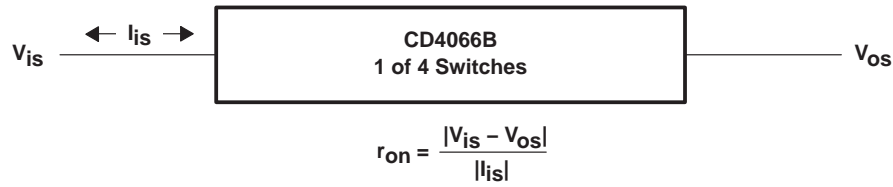

92CS-30966

Figure 6. Determination of  $r_{on}$  as a Test Condition for Control-Input High-Voltage ( $V_{IHC}$ ) Specification

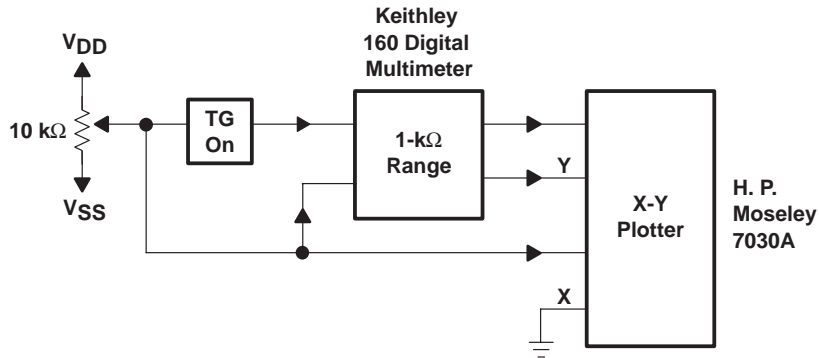

92CS-22716

Figure 7. Channel On-State Resistance Measurement Circuit

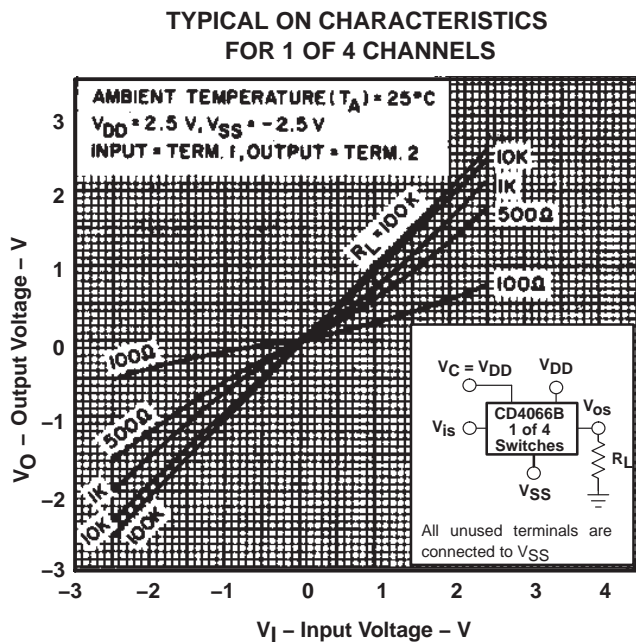

92CS-30919

Figure 8

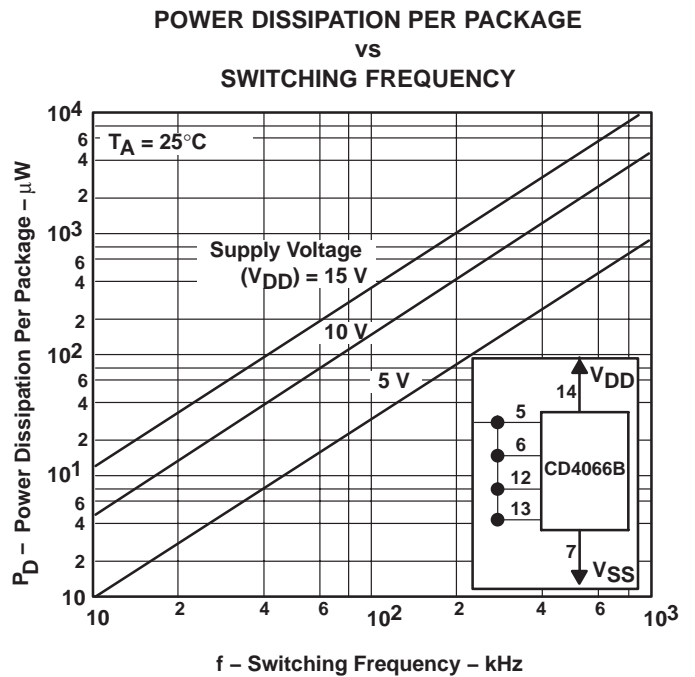

92CS-30920

Figure 9

# CD4066B CMOS QUAD BILATERAL SWITCH

SCHS051D – NOVEMBER 1998 – REVISED SEPTEMBER 2003

## TYPICAL CHARACTERISTICS

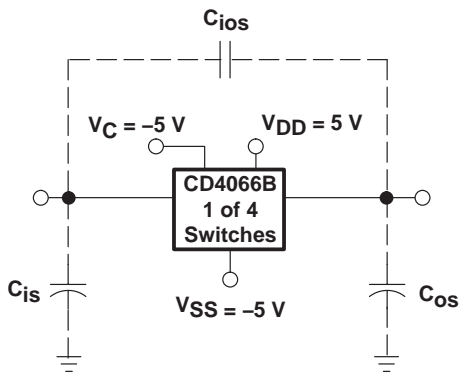

92CS-30921

Measured on Boonton capacitance bridge, model 75a (1 MHz); test-fixture capacitance nulled out.

**Figure 10. Typical On Characteristics for One of Four Channels**

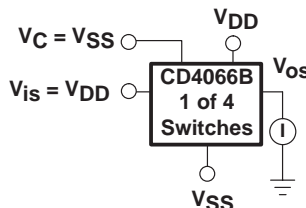

92CS-30922

All unused terminals are connected to V<sub>SS</sub>.

**Figure 11. Off-Switch Input or Output Leakage**

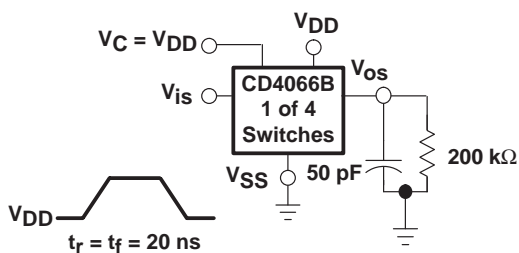

92CS-30923

All unused terminals are connected to V<sub>SS</sub>.

**Figure 12. Propagation Delay Time Signal Input (V<sub>is</sub>) to Signal Output (V<sub>os</sub>)**

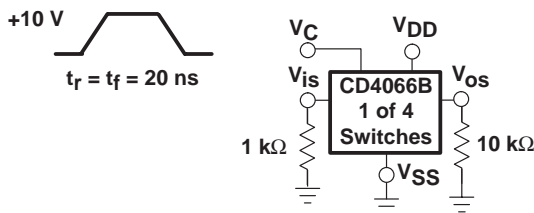

92CS-30924

All unused terminals are connected to V<sub>SS</sub>.

**Figure 13. Crosstalk-Control Input to Signal Output**



TYPICAL CHARACTERISTICS

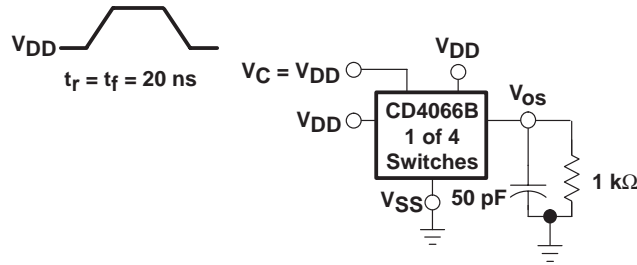

- NOTES: A. All unused terminals are connected to  $V_{SS}$ .  
B. Delay is measured at  $V_{OS}$  level of +10% from ground (turn-on) or on-state output level (turn-off).

92CS-30925

Figure 14. Propagation Delay,  $t_{PLH}$ ,  $t_{PHL}$  Control-Signal Output

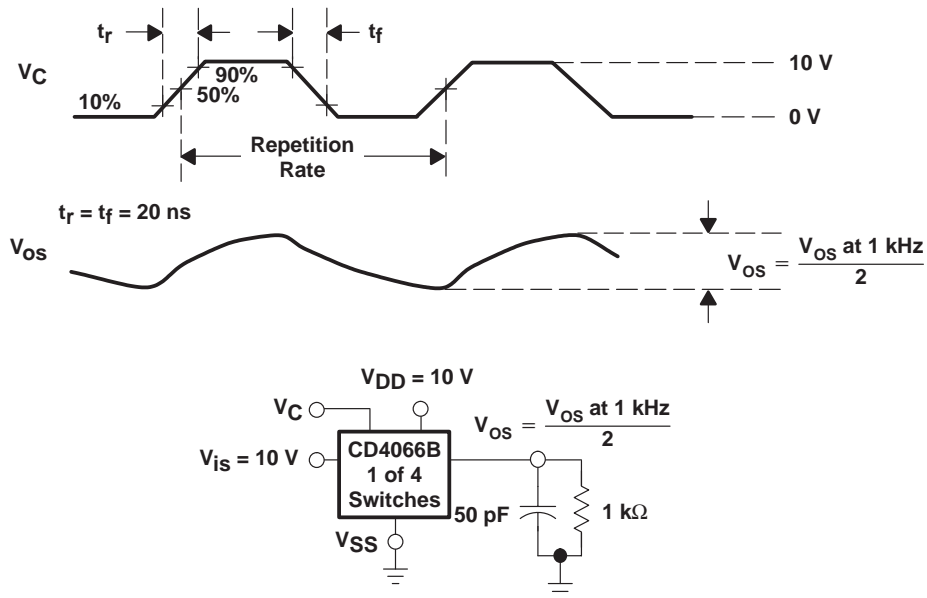

All unused terminals are connected to  $V_{SS}$ .

92CS-30925

Figure 15. Maximum Allowable Control-Input Repetition Rate

# CD4066B CMOS QUAD BILATERAL SWITCH

SCHS051D – NOVEMBER 1998 – REVISED SEPTEMBER 2003

## TYPICAL CHARACTERISTICS

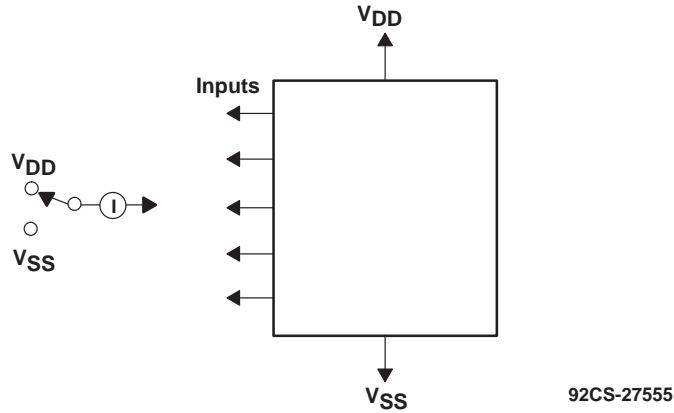

92CS-27555

Measure inputs sequentially to both  $V_{DD}$  and  $V_{SS}$ . Connect all unused inputs to either  $V_{DD}$  or  $V_{SS}$ . Measure control inputs only.

Figure 16. Input Leakage-Current Test Circuit

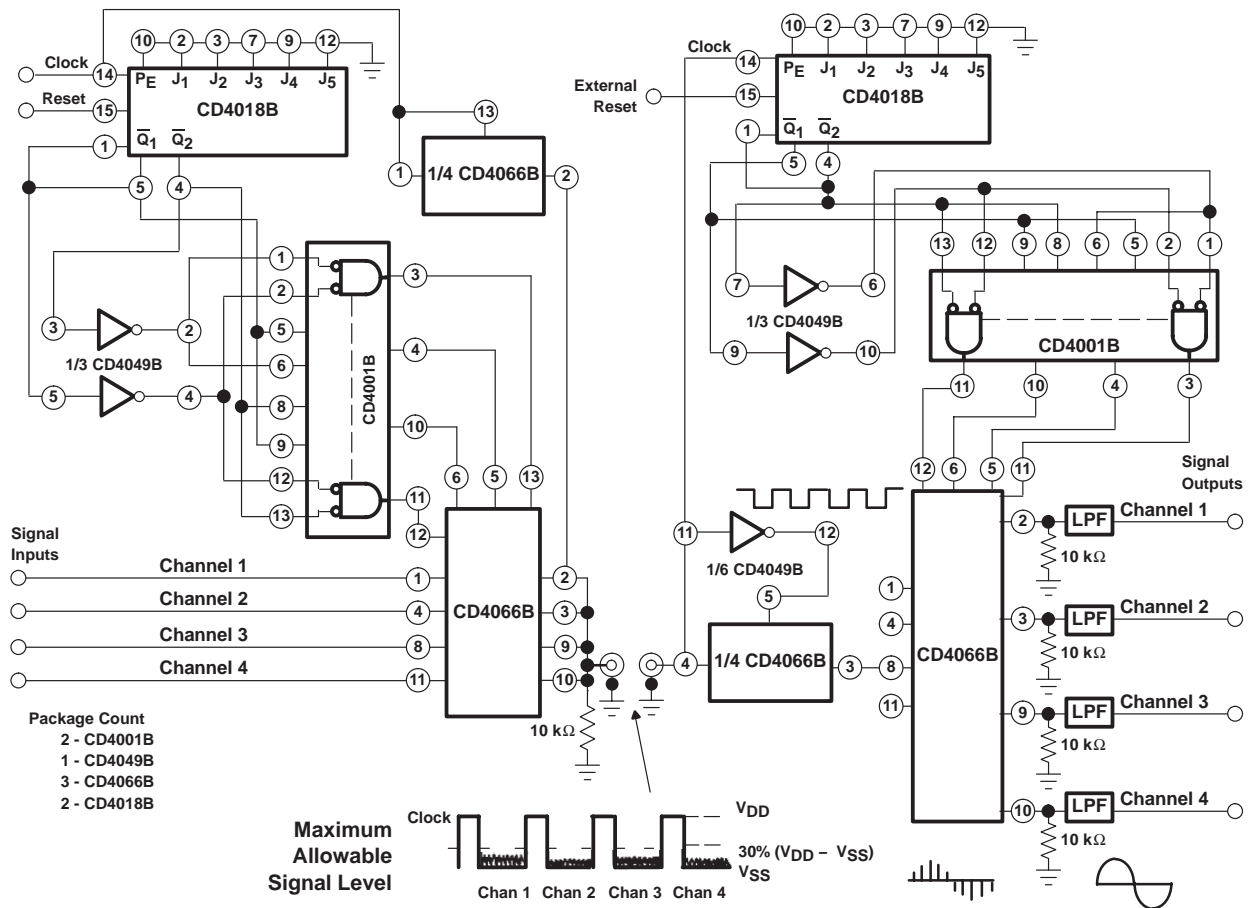

92CM-30928

Figure 17. Four-Channel PAM Multiplex System Diagram



POST OFFICE BOX 655303 • DALLAS, TEXAS 75265

**TYPICAL CHARACTERISTICS**

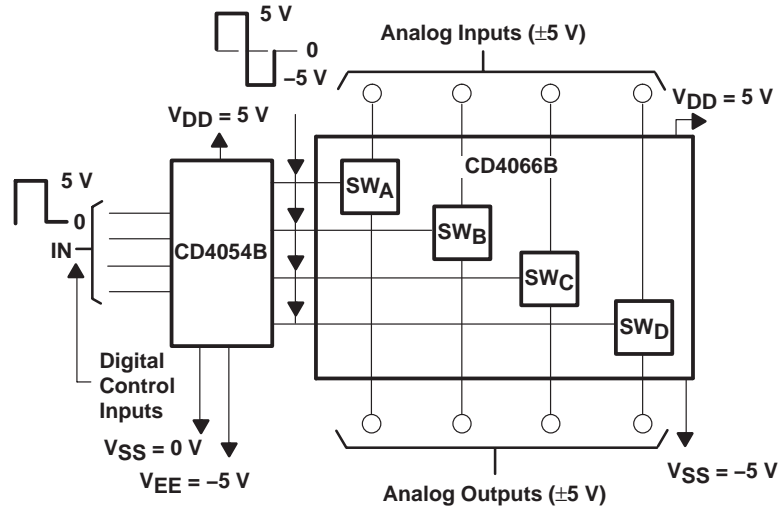

92CS-30927

**Figure 18. Bidirectional Signal Transmission Via Digital Control Logic**

# CD4066B

## CMOS QUAD BILATERAL SWITCH

SCHS051D – NOVEMBER 1998 – REVISED SEPTEMBER 2003

---

### APPLICATION INFORMATION

In applications that employ separate power sources to drive  $V_{DD}$  and the signal inputs, the  $V_{DD}$  current capability should exceed  $V_{DD}/R_L$  ( $R_L$  = effective external load of the four CD4066B bilateral switches). This provision avoids any permanent current flow or clamp action on the  $V_{DD}$  supply when power is applied or removed from the CD4066B.

In certain applications, the external load-resistor current can include both  $V_{DD}$  and signal-line components. To avoid drawing  $V_{DD}$  current when switch current flows into terminals 1, 4, 8, or 11, the voltage drop across the bidirectional switch must not exceed 0.8 V (calculated from  $r_{on}$  values shown).

No  $V_{DD}$  current will flow through  $R_L$  if the switch current flows into terminals 2, 3, 9, or 10.



POST OFFICE BOX 655303 • DALLAS, TEXAS 75265

**PACKAGING INFORMATION**

Orderable Device	Status (1)	Package Type	Package Drawing	Pins	Package Qty	Eco Plan (2)	Lead/Ball Finish (6)	MSL Peak Temp (3)	Op Temp (°C)	Device Marking (4/5)	Samples
CD4066BE	ACTIVE	PDIP	N	14	25	Pb-Free (RoHS)	CU NIPDAU	N / A for Pkg Type	-55 to 125	CD4066BE	<a href="#">Samples</a>
CD4066BEE4	ACTIVE	PDIP	N	14	25	Pb-Free (RoHS)	CU NIPDAU	N / A for Pkg Type	-55 to 125	CD4066BE	<a href="#">Samples</a>
CD4066BF	ACTIVE	CDIP	J	14	1	TBD	A42	N / A for Pkg Type	-55 to 125	CD4066BF	<a href="#">Samples</a>
CD4066BF3A	ACTIVE	CDIP	J	14	1	TBD	A42	N / A for Pkg Type	-55 to 125	CD4066BF3A	<a href="#">Samples</a>
CD4066BF3AS2283	OBSOLETE	CDIP	J	14		TBD	Call TI	Call TI			
CD4066BF3AS2534	OBSOLETE	CDIP	J	14		TBD	Call TI	Call TI			
CD4066BM	ACTIVE	SOIC	D	14	50	Green (RoHS & no Sb/Br)	CU NIPDAU	Level-1-260C-UNLIM	-55 to 125	CD4066BM	<a href="#">Samples</a>
CD4066BM96	ACTIVE	SOIC	D	14	2500	Green (RoHS & no Sb/Br)	CU NIPDAU   CU SN	Level-1-260C-UNLIM	-55 to 125	CD4066BM	<a href="#">Samples</a>
CD4066BM96E4	ACTIVE	SOIC	D	14	2500	Green (RoHS & no Sb/Br)	CU NIPDAU	Level-1-260C-UNLIM	-55 to 125	CD4066BM	<a href="#">Samples</a>
CD4066BM96G4	ACTIVE	SOIC	D	14	2500	Green (RoHS & no Sb/Br)	CU NIPDAU	Level-1-260C-UNLIM	-55 to 125	CD4066BM	<a href="#">Samples</a>
CD4066BME4	ACTIVE	SOIC	D	14	50	Green (RoHS & no Sb/Br)	CU NIPDAU	Level-1-260C-UNLIM	-55 to 125	CD4066BM	<a href="#">Samples</a>
CD4066BMG4	ACTIVE	SOIC	D	14	50	Green (RoHS & no Sb/Br)	CU NIPDAU	Level-1-260C-UNLIM	-55 to 125	CD4066BM	<a href="#">Samples</a>
CD4066BMT	ACTIVE	SOIC	D	14	250	Green (RoHS & no Sb/Br)	CU NIPDAU	Level-1-260C-UNLIM	-55 to 125	CD4066BM	<a href="#">Samples</a>
CD4066BMTE4	ACTIVE	SOIC	D	14		TBD	Call TI	Call TI	-55 to 125		<a href="#">Samples</a>
CD4066BMTG4	ACTIVE	SOIC	D	14		TBD	Call TI	Call TI	-55 to 125		<a href="#">Samples</a>
CD4066BNSR	ACTIVE	SO	NS	14	2000	Green (RoHS & no Sb/Br)	CU NIPDAU	Level-1-260C-UNLIM	-55 to 125	CD4066B	<a href="#">Samples</a>
CD4066BNSRE4	ACTIVE	SO	NS	14		TBD	Call TI	Call TI	-55 to 125		<a href="#">Samples</a>
CD4066BNSRG4	ACTIVE	SO	NS	14		TBD	Call TI	Call TI	-55 to 125		<a href="#">Samples</a>
CD4066BPW	ACTIVE	TSSOP	PW	14	90	Green (RoHS & no Sb/Br)	CU NIPDAU	Level-1-260C-UNLIM	-55 to 125	CM066B	<a href="#">Samples</a>

Orderable Device	Status (1)	Package Type	Package Drawing	Pins	Package Qty	Eco Plan (2)	Lead/Ball Finish (6)	MSL Peak Temp (3)	Op Temp (°C)	Device Marking (4/5)	Samples
CD4066BPWE4	ACTIVE	TSSOP	PW	14		TBD	Call TI	Call TI	-55 to 125		<a href="#">Samples</a>
CD4066BPWG4	ACTIVE	TSSOP	PW	14	90	Green (RoHS & no Sb/Br)	CU NIPDAU	Level-1-260C-UNLIM	-55 to 125	CM066B	<a href="#">Samples</a>
CD4066BPWR	ACTIVE	TSSOP	PW	14	2000	Green (RoHS & no Sb/Br)	CU NIPDAU	Level-1-260C-UNLIM	-55 to 125	CM066B	<a href="#">Samples</a>
CD4066BPWRE4	ACTIVE	TSSOP	PW	14		TBD	Call TI	Call TI	-55 to 125		<a href="#">Samples</a>
CD4066BPWRG4	ACTIVE	TSSOP	PW	14	2000	Green (RoHS & no Sb/Br)	CU NIPDAU	Level-1-260C-UNLIM	-55 to 125	CM066B	<a href="#">Samples</a>
JM38510/05852BCA	ACTIVE	CDIP	J	14	1	TBD	A42	N / A for Pkg Type	-55 to 125	JM38510/ 05852BCA	<a href="#">Samples</a>
M38510/05852BCA	ACTIVE	CDIP	J	14	1	TBD	A42	N / A for Pkg Type	-55 to 125	JM38510/ 05852BCA	<a href="#">Samples</a>

(1) The marketing status values are defined as follows:

**ACTIVE:** Product device recommended for new designs.

**LIFEBUY:** TI has announced that the device will be discontinued, and a lifetime-buy period is in effect.

**NRND:** Not recommended for new designs. Device is in production to support existing customers, but TI does not recommend using this part in a new design.

**PREVIEW:** Device has been announced but is not in production. Samples may or may not be available.

**OBSOLETE:** TI has discontinued the production of the device.

(2) Eco Plan - The planned eco-friendly classification: Pb-Free (RoHS), Pb-Free (RoHS Exempt), or Green (RoHS & no Sb/Br) - please check <http://www.ti.com/productcontent> for the latest availability information and additional product content details.

**TBD:** The Pb-Free/Green conversion plan has not been defined.

**Pb-Free (RoHS):** TI's terms "Lead-Free" or "Pb-Free" mean semiconductor products that are compatible with the current RoHS requirements for all 6 substances, including the requirement that lead not exceed 0.1% by weight in homogeneous materials. Where designed to be soldered at high temperatures, TI Pb-Free products are suitable for use in specified lead-free processes.

**Pb-Free (RoHS Exempt):** This component has a RoHS exemption for either 1) lead-based flip-chip solder bumps used between the die and package, or 2) lead-based die adhesive used between the die and leadframe. The component is otherwise considered Pb-Free (RoHS compatible) as defined above.

**Green (RoHS & no Sb/Br):** TI defines "Green" to mean Pb-Free (RoHS compatible), and free of Bromine (Br) and Antimony (Sb) based flame retardants (Br or Sb do not exceed 0.1% by weight in homogeneous material)

(3) MSL, Peak Temp. - The Moisture Sensitivity Level rating according to the JEDEC industry standard classifications, and peak solder temperature.

(4) There may be additional marking, which relates to the logo, the lot trace code information, or the environmental category on the device.

(5) Multiple Device Markings will be inside parentheses. Only one Device Marking contained in parentheses and separated by a "~" will appear on a device. If a line is indented then it is a continuation of the previous line and the two combined represent the entire Device Marking for that device.

<sup>(6)</sup> Lead/Ball Finish - Orderable Devices may have multiple material finish options. Finish options are separated by a vertical ruled line. Lead/Ball Finish values may wrap to two lines if the finish value exceeds the maximum column width.

**Important Information and Disclaimer:** The information provided on this page represents TI's knowledge and belief as of the date that it is provided. TI bases its knowledge and belief on information provided by third parties, and makes no representation or warranty as to the accuracy of such information. Efforts are underway to better integrate information from third parties. TI has taken and continues to take reasonable steps to provide representative and accurate information but may not have conducted destructive testing or chemical analysis on incoming materials and chemicals. TI and TI suppliers consider certain information to be proprietary, and thus CAS numbers and other limited information may not be available for release.

In no event shall TI's liability arising out of such information exceed the total purchase price of the TI part(s) at issue in this document sold by TI to Customer on an annual basis.

**OTHER QUALIFIED VERSIONS OF CD4066B, CD4066B-MIL :**

- Catalog: [CD4066B](#)
- Automotive: [CD4066B-Q1](#), [CD4066B-Q1](#)
- Military: [CD4066B-MIL](#)

NOTE: Qualified Version Definitions:

- Catalog - TI's standard catalog product
- Automotive - Q100 devices qualified for high-reliability automotive applications targeting zero defects
- Military - QML certified for Military and Defense Applications

**TAPE AND REEL INFORMATION**

**QUADRANT ASSIGNMENTS FOR PIN 1 ORIENTATION IN TAPE**

\*All dimensions are nominal

Device	Package Type	Package Drawing	Pins	SPQ	Reel Diameter (mm)	Reel Width W1 (mm)	A0 (mm)	B0 (mm)	K0 (mm)	P1 (mm)	W (mm)	Pin1 Quadrant
CD4066BM96	SOIC	D	14	2500	330.0	16.4	6.5	9.0	2.1	8.0	16.0	Q1
CD4066BM96	SOIC	D	14	2500	330.0	16.4	6.5	9.0	2.1	8.0	16.0	Q1
CD4066BM96	SOIC	D	14	2500	330.0	16.8	6.5	9.5	2.3	8.0	16.0	Q1
CD4066BM96G4	SOIC	D	14	2500	330.0	16.4	6.5	9.0	2.1	8.0	16.0	Q1
CD4066BM96G4	SOIC	D	14	2500	330.0	16.4	6.5	9.0	2.1	8.0	16.0	Q1
CD4066BMT	SOIC	D	14	250	330.0	16.4	6.5	9.0	2.1	8.0	16.0	Q1
CD4066BNSR	SO	NS	14	2000	330.0	16.4	8.2	10.5	2.5	12.0	16.0	Q1
CD4066BPWR	TSSOP	PW	14	2000	330.0	12.4	6.9	5.6	1.6	8.0	12.0	Q1



**TAPE AND REEL BOX DIMENSIONS**

\*All dimensions are nominal

Device	Package Type	Package Drawing	Pins	SPQ	Length (mm)	Width (mm)	Height (mm)
CD4066BM96	SOIC	D	14	2500	333.2	345.9	28.6
CD4066BM96	SOIC	D	14	2500	367.0	367.0	38.0
CD4066BM96	SOIC	D	14	2500	364.0	364.0	27.0
CD4066BM96G4	SOIC	D	14	2500	367.0	367.0	38.0
CD4066BM96G4	SOIC	D	14	2500	333.2	345.9	28.6
CD4066BMT	SOIC	D	14	250	367.0	367.0	38.0
CD4066BNSR	SO	NS	14	2000	367.0	367.0	38.0
CD4066BPWR	TSSOP	PW	14	2000	367.0	367.0	35.0

J (R-GDIP-T\*\*)

14 LEADS SHOWN

CERAMIC DUAL IN-LINE PACKAGE



DIM \ PINS **	14	16	18	20
A	0.300 (7,62) BSC	0.300 (7,62) BSC	0.300 (7,62) BSC	0.300 (7,62) BSC
B MAX	0.785 (19,94)	.840 (21,34)	0.960 (24,38)	1.060 (26,92)
B MIN	—	—	—	—
C MAX	0.300 (7,62)	0.300 (7,62)	0.310 (7,87)	0.300 (7,62)
C MIN	0.245 (6,22)	0.245 (6,22)	0.220 (5,59)	0.245 (6,22)



4040083/F 03/03

- NOTES:
- All linear dimensions are in inches (millimeters).
  - This drawing is subject to change without notice.
  - This package is hermetically sealed with a ceramic lid using glass frit.
  - Index point is provided on cap for terminal identification only on press ceramic glass frit seal only.
  - Falls within MIL STD 1835 GDIP1-T14, GDIP1-T16, GDIP1-T18 and GDIP1-T20.

N (R-PDIP-T\*\*)

PLASTIC DUAL-IN-LINE PACKAGE

16 PINS SHOWN



- NOTES:
- A. All linear dimensions are in inches (millimeters).
  - B. This drawing is subject to change without notice.
  - C Falls within JEDEC MS-001, except 18 and 20 pin minimum body length (Dim A).
  - D The 20 pin end lead shoulder width is a vendor option, either half or full width.

4040049/E 12/2002



D (R-PDSO-G14)

PLASTIC SMALL OUTLINE



- NOTES:
- All linear dimensions are in millimeters.
  - This drawing is subject to change without notice.
  - Publication IPC-7351 is recommended for alternate designs.
  - Laser cutting apertures with trapezoidal walls and also rounding corners will offer better paste release. Customers should contact their board assembly site for stencil design recommendations. Refer to IPC-7525 for other stencil recommendations.
  - Customers should contact their board fabrication site for solder mask tolerances between and around signal pads.

PW (R-PDSO-G14)

PLASTIC SMALL OUTLINE



- NOTES:
- A. All linear dimensions are in millimeters. Dimensioning and tolerancing per ASME Y14.5M-1994.
  - B. This drawing is subject to change without notice.
  - C. Body length does not include mold flash, protrusions, or gate burrs. Mold flash, protrusions, or gate burrs shall not exceed 0,15 each side.
  - D. Body width does not include interlead flash. Interlead flash shall not exceed 0,25 each side.
  - E. Falls within JEDEC MO-153

PW (R-PDSO-G14)

PLASTIC SMALL OUTLINE

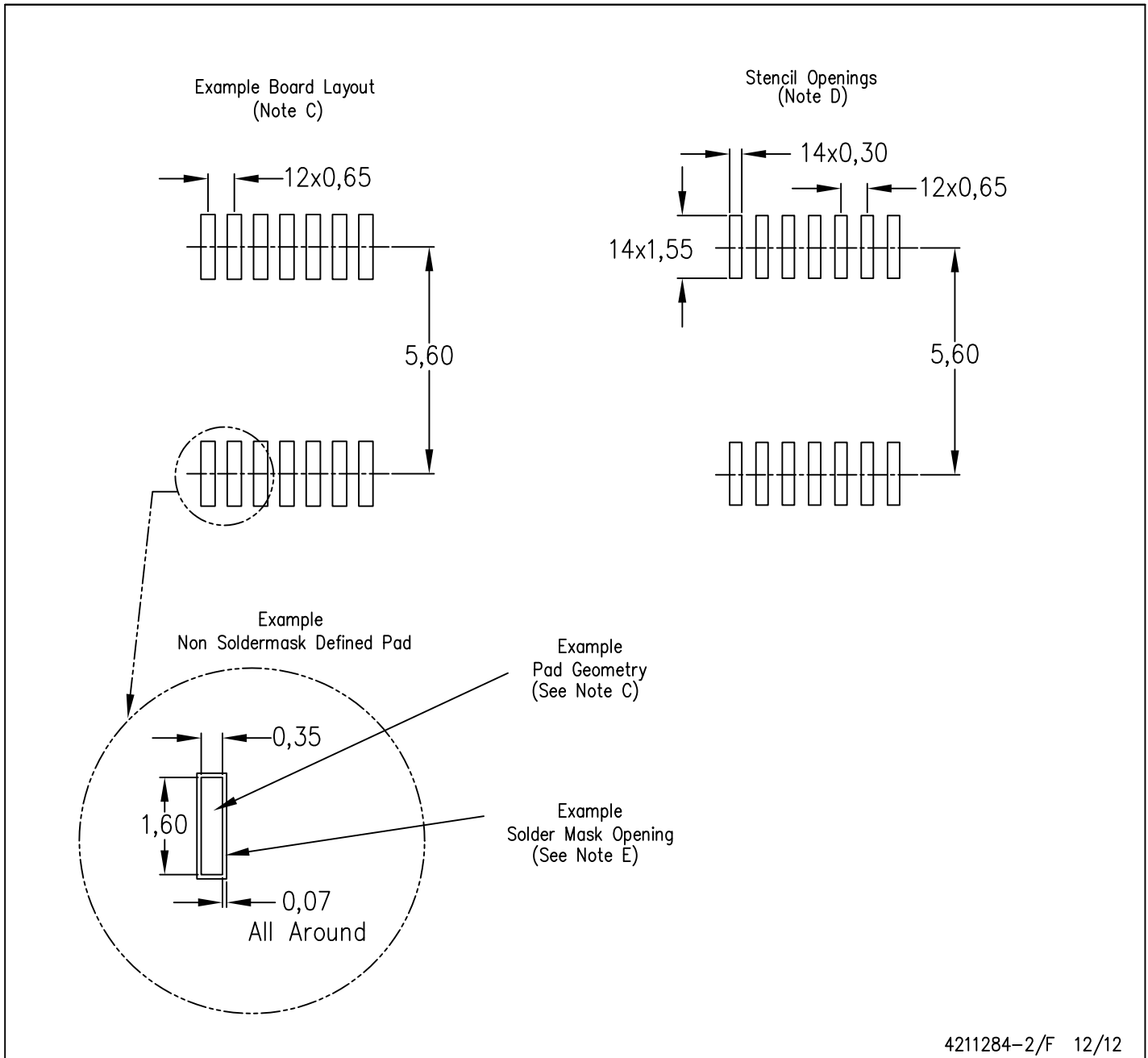

- NOTES:
- A. All linear dimensions are in millimeters.
  - B. This drawing is subject to change without notice.
  - C. Publication IPC-7351 is recommended for alternate designs.
  - D. Laser cutting apertures with trapezoidal walls and also rounding corners will offer better paste release. Customers should contact their board assembly site for stencil design recommendations. Refer to IPC-7525 for other stencil recommendations.
  - E. Customers should contact their board fabrication site for solder mask tolerances between and around signal pads.

# MECHANICAL DATA

NS (R-PDSO-G\*\*)

PLASTIC SMALL-OUTLINE PACKAGE

14-PINS SHOWN



- NOTES:
- A. All linear dimensions are in millimeters.
  - B. This drawing is subject to change without notice.
  - C. Body dimensions do not include mold flash or protrusion, not to exceed 0,15.



## IMPORTANT NOTICE

Texas Instruments Incorporated and its subsidiaries (TI) reserve the right to make corrections, enhancements, improvements and other changes to its semiconductor products and services per JESD46, latest issue, and to discontinue any product or service per JESD48, latest issue. Buyers should obtain the latest relevant information before placing orders and should verify that such information is current and complete. All semiconductor products (also referred to herein as "components") are sold subject to TI's terms and conditions of sale supplied at the time of order acknowledgment.

TI warrants performance of its components to the specifications applicable at the time of sale, in accordance with the warranty in TI's terms and conditions of sale of semiconductor products. Testing and other quality control techniques are used to the extent TI deems necessary to support this warranty. Except where mandated by applicable law, testing of all parameters of each component is not necessarily performed.

TI assumes no liability for applications assistance or the design of Buyers' products. Buyers are responsible for their products and applications using TI components. To minimize the risks associated with Buyers' products and applications, Buyers should provide adequate design and operating safeguards.

TI does not warrant or represent that any license, either express or implied, is granted under any patent right, copyright, mask work right, or other intellectual property right relating to any combination, machine, or process in which TI components or services are used. Information published by TI regarding third-party products or services does not constitute a license to use such products or services or a warranty or endorsement thereof. Use of such information may require a license from a third party under the patents or other intellectual property of the third party, or a license from TI under the patents or other intellectual property of TI.

Reproduction of significant portions of TI information in TI data books or data sheets is permissible only if reproduction is without alteration and is accompanied by all associated warranties, conditions, limitations, and notices. TI is not responsible or liable for such altered documentation. Information of third parties may be subject to additional restrictions.

Resale of TI components or services with statements different from or beyond the parameters stated by TI for that component or service voids all express and any implied warranties for the associated TI component or service and is an unfair and deceptive business practice. TI is not responsible or liable for any such statements.

Buyer acknowledges and agrees that it is solely responsible for compliance with all legal, regulatory and safety-related requirements concerning its products, and any use of TI components in its applications, notwithstanding any applications-related information or support that may be provided by TI. Buyer represents and agrees that it has all the necessary expertise to create and implement safeguards which anticipate dangerous consequences of failures, monitor failures and their consequences, lessen the likelihood of failures that might cause harm and take appropriate remedial actions. Buyer will fully indemnify TI and its representatives against any damages arising out of the use of any TI components in safety-critical applications.

In some cases, TI components may be promoted specifically to facilitate safety-related applications. With such components, TI's goal is to help enable customers to design and create their own end-product solutions that meet applicable functional safety standards and requirements. Nonetheless, such components are subject to these terms.

No TI components are authorized for use in FDA Class III (or similar life-critical medical equipment) unless authorized officers of the parties have executed a special agreement specifically governing such use.

Only those TI components which TI has specifically designated as military grade or "enhanced plastic" are designed and intended for use in military/aerospace applications or environments. Buyer acknowledges and agrees that any military or aerospace use of TI components which have **not** been so designated is solely at the Buyer's risk, and that Buyer is solely responsible for compliance with all legal and regulatory requirements in connection with such use.

TI has specifically designated certain components as meeting ISO/TS16949 requirements, mainly for automotive use. In any case of use of non-designated products, TI will not be responsible for any failure to meet ISO/TS16949.

### Products

Audio	<a href="http://www.ti.com/audio">www.ti.com/audio</a>
Amplifiers	<a href="http://amplifier.ti.com">amplifier.ti.com</a>
Data Converters	<a href="http://dataconverter.ti.com">dataconverter.ti.com</a>
DLP® Products	<a href="http://www.dlp.com">www.dlp.com</a>
DSP	<a href="http://dsp.ti.com">dsp.ti.com</a>
Clocks and Timers	<a href="http://www.ti.com/clocks">www.ti.com/clocks</a>
Interface	<a href="http://interface.ti.com">interface.ti.com</a>
Logic	<a href="http://logic.ti.com">logic.ti.com</a>
Power Mgmt	<a href="http://power.ti.com">power.ti.com</a>
Microcontrollers	<a href="http://microcontroller.ti.com">microcontroller.ti.com</a>
RFID	<a href="http://www.ti-rfid.com">www.ti-rfid.com</a>
OMAP Applications Processors	<a href="http://www.ti.com/omap">www.ti.com/omap</a>
Wireless Connectivity	<a href="http://www.ti.com/wirelessconnectivity">www.ti.com/wirelessconnectivity</a>

### Applications

Automotive and Transportation	<a href="http://www.ti.com/automotive">www.ti.com/automotive</a>
Communications and Telecom	<a href="http://www.ti.com/communications">www.ti.com/communications</a>
Computers and Peripherals	<a href="http://www.ti.com/computers">www.ti.com/computers</a>
Consumer Electronics	<a href="http://www.ti.com/consumer-apps">www.ti.com/consumer-apps</a>
Energy and Lighting	<a href="http://www.ti.com/energy">www.ti.com/energy</a>
Industrial	<a href="http://www.ti.com/industrial">www.ti.com/industrial</a>
Medical	<a href="http://www.ti.com/medical">www.ti.com/medical</a>
Security	<a href="http://www.ti.com/security">www.ti.com/security</a>
Space, Avionics and Defense	<a href="http://www.ti.com/space-avionics-defense">www.ti.com/space-avionics-defense</a>
Video and Imaging	<a href="http://www.ti.com/video">www.ti.com/video</a>

### TI E2E Community

[e2e.ti.com](http://e2e.ti.com)