

STR2000 Series

Switching Type — Chopper • Self Oscillation Type

Features

- Requires only 3 external components
- Small size and high efficiency
- Low switching noise
- Variable output voltage
- Use of SANKEN's semiconductor elements ensures high reliability

Applications

- For power supplies in office equipment such as electronic typewriters, printers, and copiers
- For power supplies in VCRs and personal CB radios (fixed station)

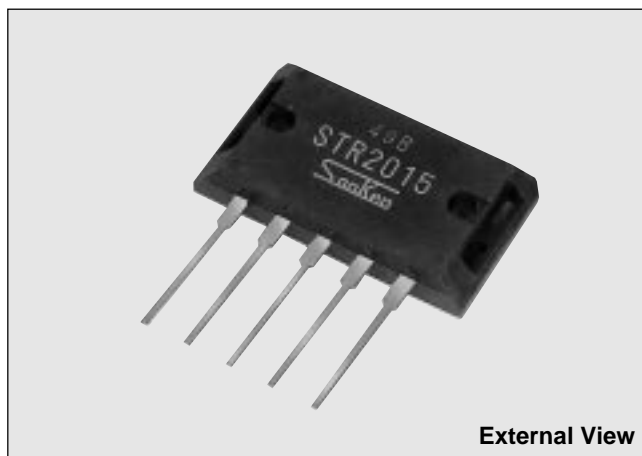

Absolute Maximum Ratings (Ta=25°C)

Parameter	Symbol	Ratings					Unit
		STR2005	STR2012	STR2013	STR2015	STR2024	
DC Input Voltage	V _{IN}	45				50	V
DC Output Current	I _o	2.0 (pulse 3.0)					A
Power Dissipation	P _D	75 (T _C =25°C)					W
		15 (T _C =100°C)					
Operating Temperature	T _{op}	-20 to +100					°C
Storage Temperature	T _{stg}	-20 to +125					°C
Thermal Resistance (junction-to-case)	R _{th(j-c)}	1.25					°C/W

Electrical Characteristics (Ta=25°C)

Parameter	Symbol	Ratings															Unit
		STR2005			STR2012			STR2013			STR2015			STR2024			
		min	typ	max	min	typ	max	min	typ	max	min	typ	max	min	typ	max	
DC Input Voltage Range	V _{IN}	11		40	18		45	19		45	21		45	30		50	V
	Condition	I _o =1.0A															
Output Voltage	V _o	5.0	5.1	5.2	11.8	12.0	12.2	12.8	13.0	13.2	14.8	15.0	15.2	23.7	24.0	24.3	V
	Condition	V _{IN} =20V, I _o =1.0A			V _{IN} =24V, I _o =1.0A			V _{IN} =27V, I _o =1.0A			V _{IN} =35V, I _o =1.0A						
Efficiency	η		72			85			85			85			85		%
	Condition	V _{IN} =20V, I _o =1.0A			V _{IN} =24V, I _o =1.0A			V _{IN} =27V, I _o =1.0A			V _{IN} =35V, I _o =1.0A						
Line Regulation	ΔV _{OLINE}			50			60			60			60			60	mV
	Condition	V _{IN} =15 to 25V, I _o =1.0A			V _{IN} =20 to 28V, I _o =1.0A			V _{IN} =23 to 31V, I _o =1.0A			V _{IN} =30 to 40V, I _o =1.0A						
Load Regulation	ΔV _{OLOAD}			100			100			100			100			100	mV
	Condition	V _{IN} =20V, I _o =0.5 to 1.5A			V _{IN} =24V, I _o =0.5 to 1.5A			V _{IN} =27V, I _o =0.5 to 1.5A			V _{IN} =35V, I _o =0.5 to 1.5A						
Ripple Rejection	R _{REJ}		45			45			45			45			45		dB
	Condition	f=100 to 120Hz															
Switching Frequency	f		25			25			25			25			25		kHz
	Condition	V _{IN} =20V, I _o =1.0A			V _{IN} =24V, I _o =1.0A			V _{IN} =27V, I _o =1.0A			V _{IN} =35V, I _o =1.0A						

STR2000 Series

■ Outline Drawing/Terminal Connections (unit:mm)

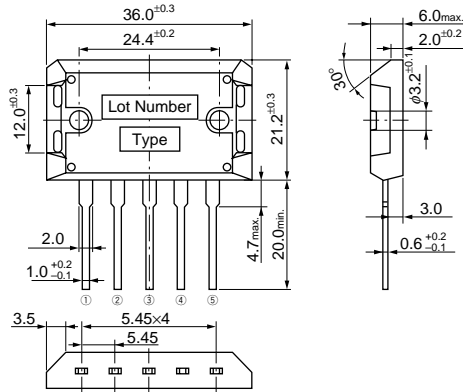

Plastic Mold Package Type
Flammability: UL94V-0

Terminal Connections

- ① Switching Output (backside of case)
- ② Output Voltage Adjustment
- ③ Ground
- ④ Output Voltage Detection
- ⑤ Input

Weight: Approx. 14.5g

■ Block Diagram

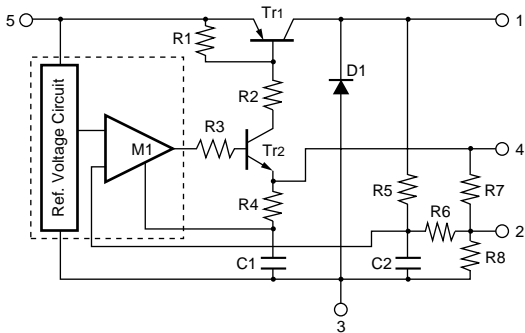

■ Ta-PD Characteristics

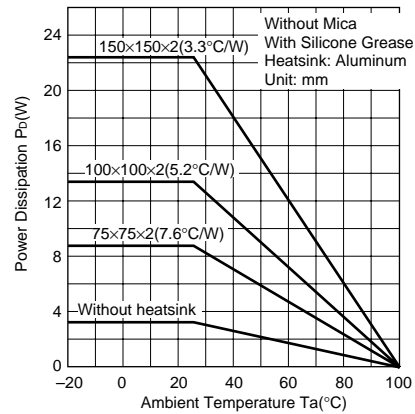

■ Standard External Circuit

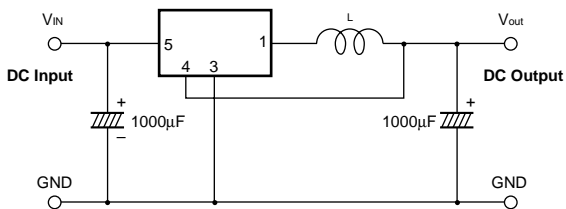

Type	Inductance L
STR2005	200µH
STR2012	300µH
STR2013	300µH
STR2015	350µH
STR2024	400µH

■ Variable Output Voltage Circuit

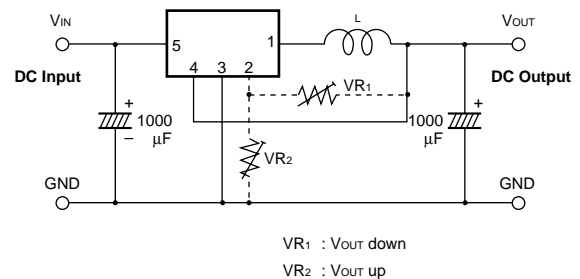

STR2000 Series Typical Characteristics (Ta=25°C)

STR2005

Rise Characteristics

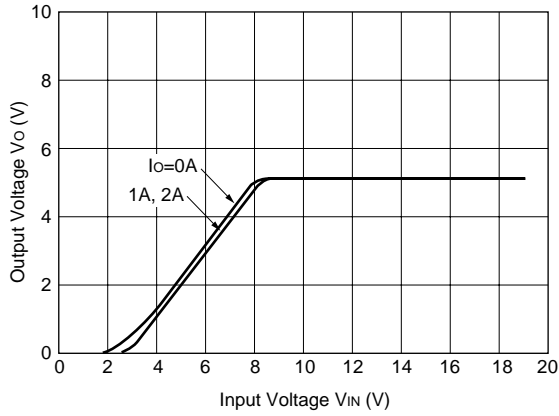

Efficiency Characteristics

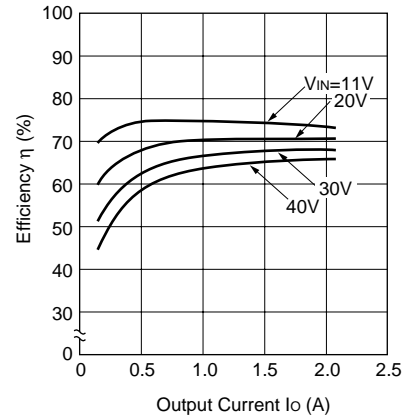

STR2012

Rise Characteristics

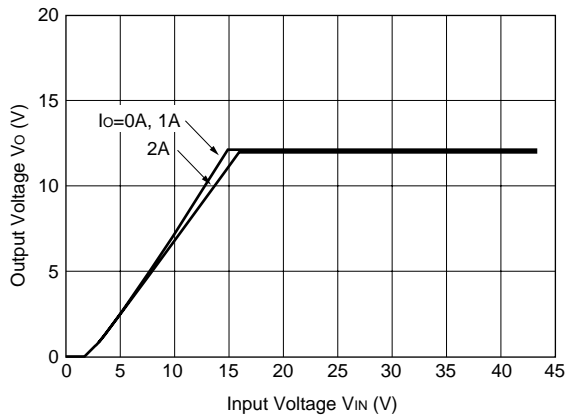

Efficiency Characteristics

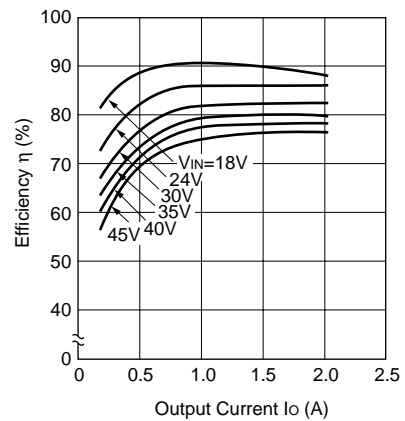

STR2024

Rise Characteristics

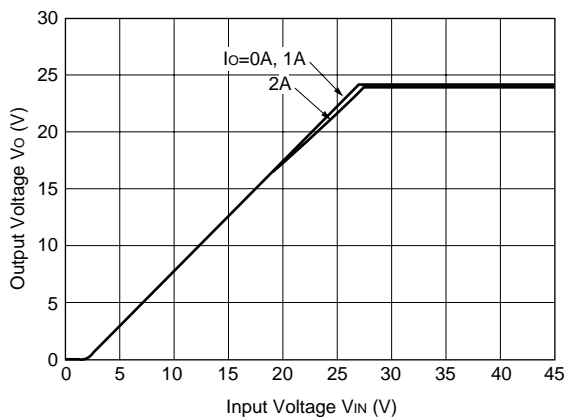

Efficiency Characteristics

