

LM2578A/LM3578A Switching Regulator

 Check for Samples: [LM2578A](#), [LM3578A](#)

FEATURES

- Inverting and Non-Inverting Feedback Inputs
- 1.0V Reference at Inputs
- Operates from Supply Voltages of 2V to 40V
- Output Current up to 750 mA, Saturation Less than 0.9V
- Current Limit and Thermal Shut Down
- Duty Cycle up to 90%

APPLICATIONS

- Switching Regulators in Buck, Boost, Inverting, and Single-Ended Transformer Configurations
- Motor Speed Control
- Lamp Flasher

DESCRIPTION

The LM2578A is a switching regulator which can easily be set up for such DC-to-DC voltage conversion circuits as the buck, boost, and inverting configurations. The LM2578A features a unique comparator input stage which not only has separate pins for both the inverting and non-inverting inputs, but also provides an internal 1.0V reference to each input, thereby simplifying circuit design and p.c. board layout. The output can switch up to 750 mA and has output pins for its collector and emitter to promote design flexibility. An external current limit terminal may be referenced to either the ground or the V_{in} terminal, depending upon the application. In addition, the LM2578A has an on board oscillator, which sets the switching frequency with a single external capacitor from <1 Hz to 100 kHz (typical).

The LM2578A is an improved version of the LM2578, offering higher maximum ratings for the total supply voltage and output transistor emitter and collector voltages.

Connection Diagram

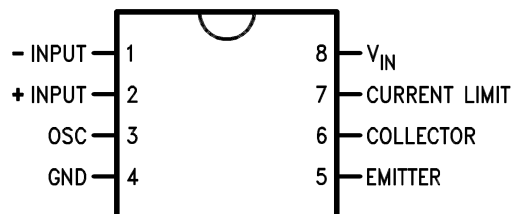

Figure 1. PDIP/SOIC Package
See Package Number D0008A or P0008E



Please be aware that an important notice concerning availability, standard warranty, and use in critical applications of Texas Instruments semiconductor products and disclaimers thereto appears at the end of this data sheet.

All trademarks are the property of their respective owners.

Functional Diagram

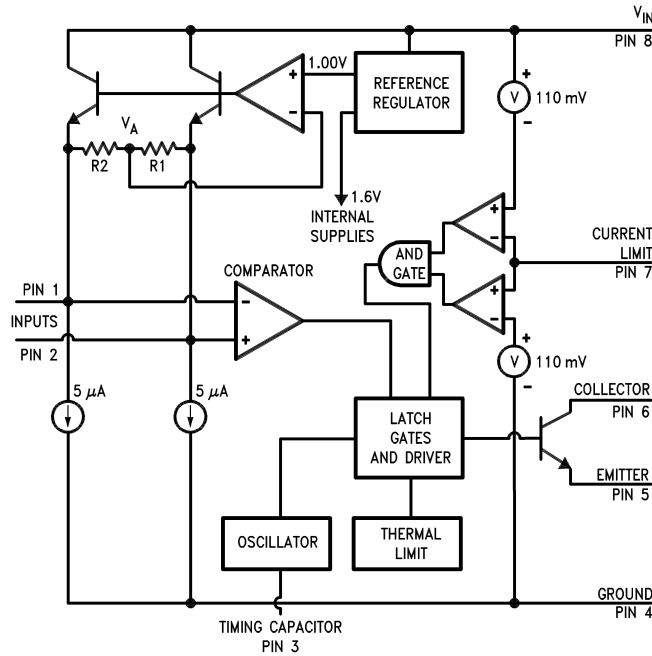

These devices have limited built-in ESD protection. The leads should be shorted together or the device placed in conductive foam during storage or handling to prevent electrostatic damage to the MOS gates.

Absolute Maximum Ratings ⁽¹⁾⁽²⁾

Total Supply Voltage		50V
Collector Output to Ground		-0.3V to +50V
Emitter Output to Ground ⁽³⁾		-1V to +50V
Power Dissipation ⁽⁴⁾		Internally limited
Output Current		750 mA
Storage Temperature		-65°C to +150°C
Lead Temperature	(soldering, 10 seconds)	260°C
Maximum Junction Temperature		150°C
ESD Tolerance ⁽⁵⁾		2 kV

- (1) Absolute Maximum Ratings indicate limits beyond which damage to the device may occur. DC and AC electrical specifications do not apply when operating the device beyond its rated operating conditions.
- (2) If Military/Aerospace specified devices are required, please contact the Texas Instruments Sales Office/ Distributors for availability and specifications.
- (3) For $T_J \geq 100^\circ\text{C}$, the Emitter pin voltage should not be driven more than 0.6V below ground (see [Application Information](#)).
- (4) At elevated temperatures, devices must be derated based on package thermal resistance. The device in the 8-pin DIP must be derated at 95°C/W , junction to ambient. The device in the SOIC package must be derated at 150°C/W , junction-to-ambient.
- (5) Human body model, 1.5 kΩ in series with 100 pF.

Operating Ratings

Ambient Temperature Range	LM2578A	$-40^\circ\text{C} \leq T_A \leq +85^\circ\text{C}$
	LM3578A	$0^\circ\text{C} \leq T_A \leq +70^\circ\text{C}$
Junction Temperature Range	LM2578A	$-40^\circ\text{C} \leq T_J \leq +125^\circ\text{C}$
	LM3578A	$0^\circ\text{C} \leq T_J \leq +125^\circ\text{C}$

Electrical Characteristics

These specifications apply for $2V \leq V_{IN} \leq 40V$ ($2.2V \leq V_{IN} \leq 40V$ for $T_J \leq -25^\circ C$), timing capacitor $C_T = 3900$ pF, and $25\% \leq$ duty cycle $\leq 75\%$, unless otherwise specified. Values in standard typeface are for $T_J = 25^\circ C$; values in **boldface type** apply for operation over the specified operating junction temperature range.

Symbol	Parameter	Conditions	Typical ⁽¹⁾	LM2578A/ LM3578A Limit ⁽²⁾	Units
OSCILLATOR					
f_{OSC}	Frequency		20	24 16	kHz kHz (max) kHz (min)
$\Delta f_{OSC}/\Delta T$	Frequency Drift with Temperature		-0.13		%/°C
	Amplitude		550		mV _{pp}
REFERENCE/COMPARATOR⁽³⁾					
V_R	Input Reference Voltage	$I_1 = I_2 = 0$ mA and $I_1 = I_2 = 1$ mA $\pm 1\%$ ⁽⁴⁾	1.0	1.050/ 1.070 0.950/ 0.930	V V (max) V (min)
$\Delta V_R/\Delta V_{IN}$	Input Reference Voltage Line Regulation	$I_1 = I_2 = 0$ mA and $I_1 = I_2 = 1$ mA $\pm 1\%$ ⁽⁴⁾	0.003	0.01/ 0.02	%/V %/V (max)
I_{INV}	Inverting Input Current	$I_1 = I_2 = 0$ mA, duty cycle = 25%	0.5		μA
	Level Shift Accuracy	Level Shift Current = 1 mA	1.0	10/ 13	% % (max)
$\Delta V_R/\Delta t$	Input Reference Voltage Long Term Stability		100		ppm/1000h
OUTPUT					
V_C (sat)	Collector Saturation Voltage	$I_C = 750$ mA pulsed, Emitter grounded	0.7	0.90/ 1.2	V V (max)
V_E (sat)	Emitter Saturation Voltage	$I_O = 80$ mA pulsed, $V_{IN} = V_C = 40V$	1.4	1.7/ 2.0	V V (max)
I_{CES}	Collector Leakage Current	$V_{IN} = V_{CE} = 40V$, Emitter grounded, Output OFF	0.1	200/ 250	μA μA (max)
$BV_{CEO(SUS)}$	Collector-Emitter Sustaining Voltage	$I_{SUST} = 0.2A$ (pulsed), $V_{IN} = 0$	60	50	V V (min)
CURRENT LIMIT					
V_{CL}	Sense Voltage Shutdown Level	Referred to V_{IN} or Ground See ⁽⁵⁾	110	80 160	mV mV (min) mV (max)
$\Delta V_{CL}/\Delta T$	Sense Voltage Temperature Drift		0.3		%/°C
I_{CL}	Sense Bias Current	Referred to V_{IN} Referred to ground	4.0 0.4		μA μA

(1) Typical values are for $T_J = 25^\circ C$ and represent the most likely parametric norm.

(2) All limits specified at room temperature (standard type face) and at temperature extremes (bold type face). Room temperature limits are 100% production tested. Limits at temperature extremes are specified via correlation using standard Statistical Quality Control (SQC) methods. All limits are used to calculate AOQL.

(3) Input terminals are protected from accidental shorts to ground but if external voltages higher than the reference voltage are applied, excessive current will flow and should be limited to less than 5 mA.

(4) I_1 and I_2 are the external sink currents at the inputs (refer to [Test Circuit](#)).

(5) Connection of a 10 k Ω resistor from pin 1 to pin 4 will drive the duty cycle to its maximum, typically 90%. Applying the minimum Current Limit Sense Voltage to pin 7 will not reduce the duty cycle to less than 50%. Applying the maximum Current Limit Sense Voltage to pin 7 is certain to reduce the duty cycle below 50%. Increasing this voltage by 15 mV may be required to reduce the duty cycle to 0%, when the Collector output swing is 40V or greater (see [Ground-Referred Current Limit Sense Voltage](#) typical curve).

Electrical Characteristics (continued)

These specifications apply for $2V \leq V_{IN} \leq 40V$ ($2.2V \leq V_{IN} \leq 40V$ for $T_J \leq -25^\circ C$), timing capacitor $C_T = 3900$ pF, and $25\% \leq$ duty cycle $\leq 75\%$, unless otherwise specified. Values in standard typeface are for $T_J = 25^\circ C$; values in **boldface type** apply for operation over the specified operating junction temperature range.

Symbol	Parameter	Conditions	Typical ⁽¹⁾	LM2578A/ LM3578A Limit ⁽²⁾	Units
DEVICE POWER CONSUMPTION					
I_S	Supply Current	Output OFF, $V_E = 0V$	2.0	3.5/4.0	mA
		Output ON, $I_C = 750$ mA pulsed, $V_E = 0V$	14		mA (max)
					mA

Typical Performance Characteristics

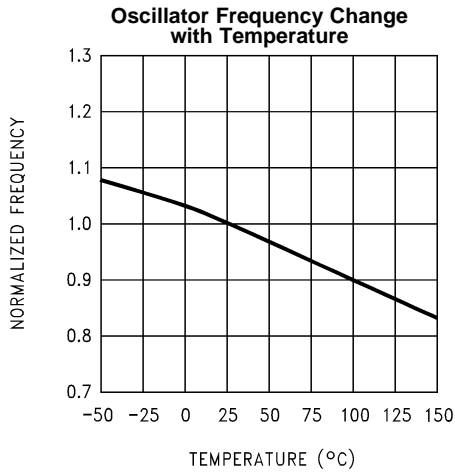

Figure 2.

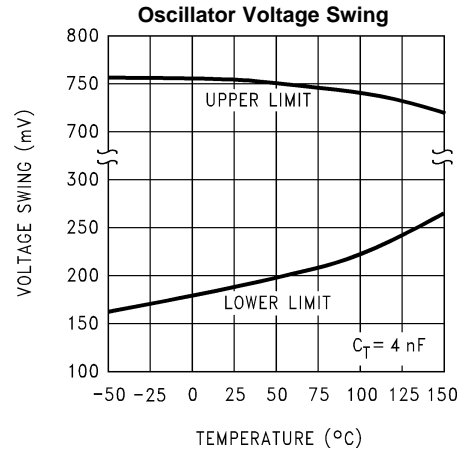

Figure 3.

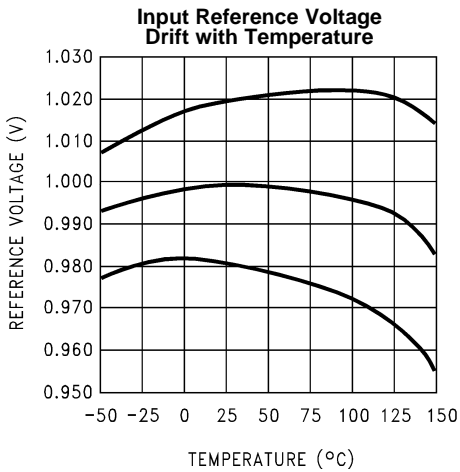

Figure 4.

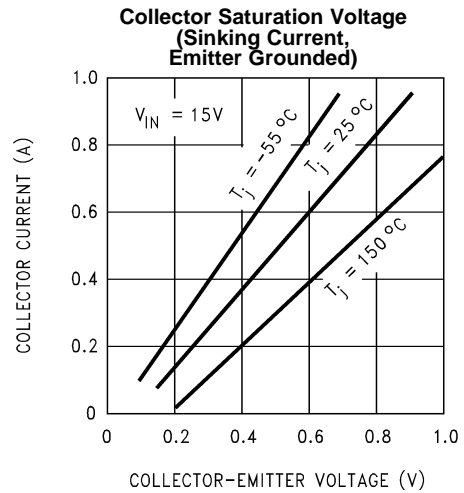

Figure 5.

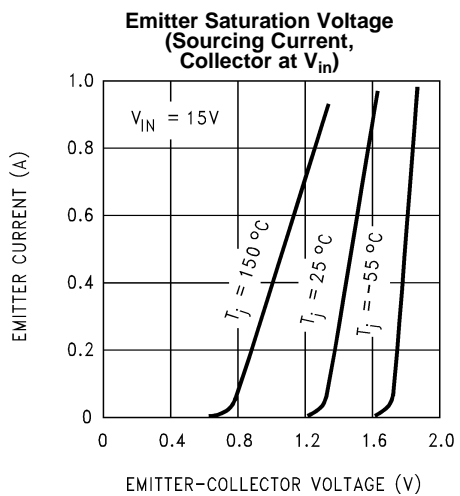

Figure 6.

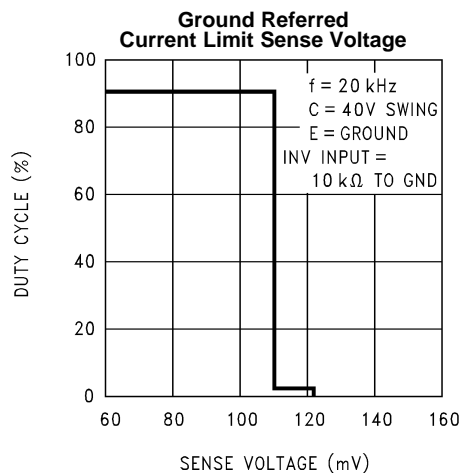

Figure 7.

Typical Performance Characteristics (continued)

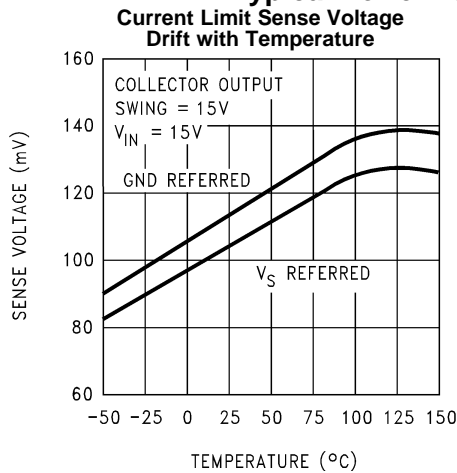

Figure 8.

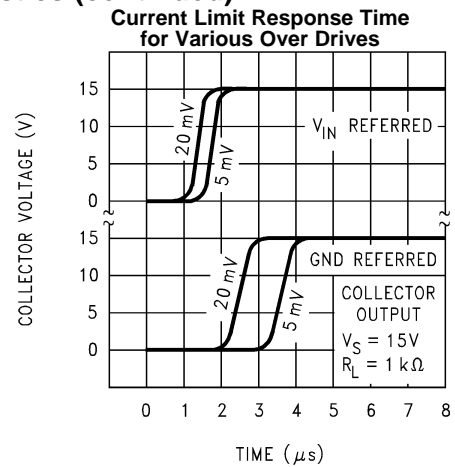

Figure 9.

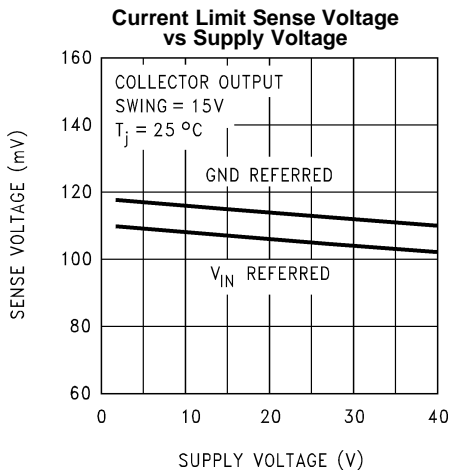

Figure 10.

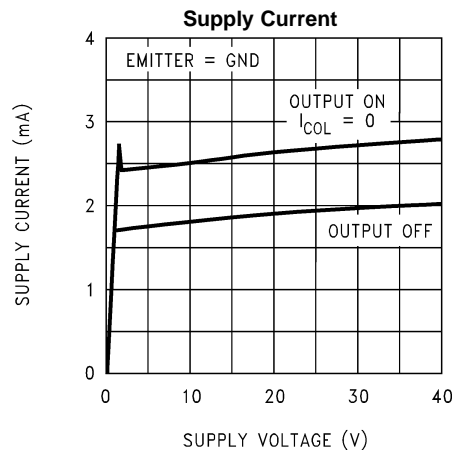

Figure 11.

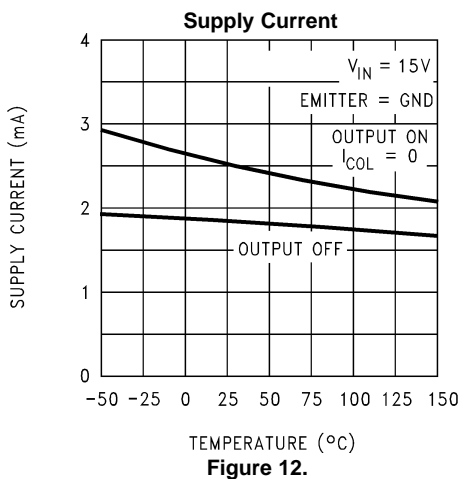

Figure 12.

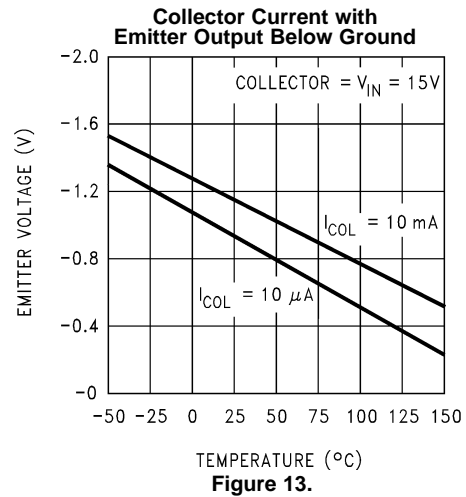

Figure 13.

TEST CIRCUIT*

Parameter tests can be made using the test circuit shown. Select the desired V_{in} , collector voltage and duty cycle with adjustable power supplies. A digital volt meter with an input resistance greater than 100 M Ω should be used to measure the following:

Input Reference Voltage to Ground; S1 in either position.

Level Shift Accuracy (%) = $(T_{P3}(V)/1V) \times 100\%$; S1 at $I_1 = I_2 = 1 \text{ mA}$

Input Current (mA) = $(1V - T_{P3}(V))/1 \text{ M}\Omega$; S1 at $I_1 = I_2 = 0 \text{ mA}$.

Oscillator parameters can be measured at T_{P4} using a frequency counter or an oscilloscope.

The Current Limit Sense Voltage is measured by connecting an adjustable 0-to-1V floating power supply in series with the current limit terminal and referring it to either the ground or the V_{in} terminal. Set the duty cycle to 90% and monitor test point T_{P5} while adjusting the floating power supply voltage until the LM2578A's duty cycle just reaches 0%. This voltage is the Current Limit Sense Voltage.

The Supply Current should be measured with the duty cycle at 0% and S1 in the $I_1 = I_2 = 0 \text{ mA}$ position.

*LM2578A specifications are measured using automated test equipment. This circuit is provided for the customer's convenience when checking parameters. Due to possible variations in testing conditions, the measured values from these testing procedures may not match those of the factory.

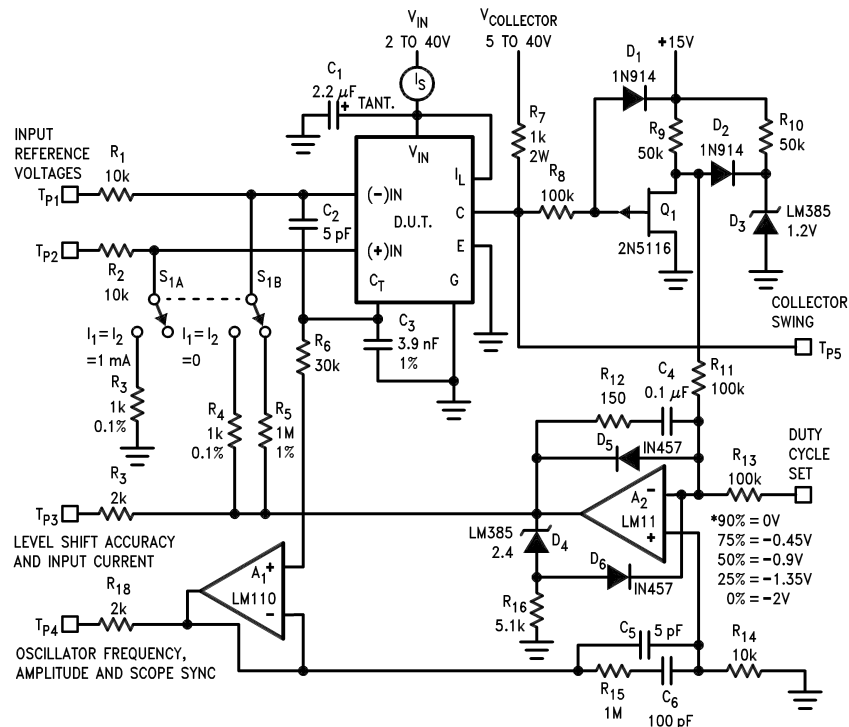

Op amp supplies are $\pm 15V$
 DVM input resistance >100 M Ω
 *LM2578 max duty cycle is 90%

Definition of Terms

Input Reference Voltage: The voltage (referred to ground) that must be applied to either the inverting or non-inverting input to cause the regulator switch to change state (ON or OFF).

Input Reference Current: The current that must be drawn from either the inverting or non-inverting input to cause the regulator switch to change state (ON or OFF).

Input Level Shift Accuracy: This specification determines the output voltage tolerance of a regulator whose output control depends on drawing equal currents from the inverting and non-inverting inputs (see the Inverting Regulator of [Figure 34](#), and the RS-232 Line Driver Power Supply of [Figure 36](#)).

Level Shift Accuracy is tested by using two equal-value resistors to draw current from the inverting and non-inverting input terminals, then measuring the percentage difference in the voltages across the resistors that produces a controlled duty cycle at the switch output.

Collector Saturation Voltage: With the inverting input terminal grounded thru a 10 kΩ resistor and the output transistor's emitter connected to ground, the Collector Saturation Voltage is the collector-to-emitter voltage for a given collector current.

Emitter Saturation Voltage: With the inverting input terminal grounded thru a 10 kΩ resistor and the output transistor's collector connected to V_{in} , the Emitter Saturation Voltage is the collector-to-emitter voltage for a given emitter current.

Collector Emitter Sustaining Voltage: The collector-emitter breakdown voltage of the output transistor, measured at a specified current.

Current Limit Sense Voltage: The voltage at the Current Limit pin, referred to either the supply or the ground terminal, which (via logic circuitry) will cause the output transistor to turn OFF and resets cycle-by-cycle at the oscillator frequency.

Current Limit Sense Current: The bias current for the Current Limit terminal with the applied voltage equal to the Current Limit Sense Voltage.

Supply Current: The IC power supply current, excluding the current drawn through the output transistor, with the oscillator operating.

Functional Description

The LM2578A is a pulse-width modulator designed for use as a switching regulator controller. It may also be used in other applications which require controlled pulse-width voltage drive.

A control signal, usually representing output voltage, fed into the LM2578A's comparator is compared with an internally-generated reference. The resulting error signal and the oscillator's output are fed to a logic network which determines when the output transistor will be turned ON or OFF. The following is a brief description of the subsections of the LM2578A.

COMPARATOR INPUT STAGE

The LM2578A's comparator input stage is unique in that both the inverting and non-inverting inputs are available to the user, and both contain a 1.0V reference. This is accomplished as follows: A 1.0V reference is fed into a modified voltage follower circuit (see [FUNCTIONAL DIAGRAM](#)). When both input pins are open, no current flows through R1 and R2. Thus, both inputs to the comparator will have the potential of the 1.0V reference, V_A . When one input, for example the non-inverting input, is pulled ΔV away from V_A , a current of $\Delta V/R1$ will flow through R1. This same current flows through R2, and the comparator sees a total voltage of $2\Delta V$ between its inputs. The high gain of the system, through feedback, will correct for this imbalance and return both inputs to the 1.0V level.

This unusual comparator input stage increases circuit flexibility, while minimizing the total number of external components required for a voltage regulator system. The inverting switching regulator configuration, for example, can be set up without having to use an external op amp for feedback polarity reversal (see [TYPICAL APPLICATIONS](#)).

OSCILLATOR

The LM2578A provides an on-board oscillator which can be adjusted up to 100 kHz. Its frequency is set by a single external capacitor, C_1 , as shown in [Figure 14](#), and follows the equation

$$f_{OSC} = 8 \times 10^{-5} / C_1$$

The oscillator provides a blanking pulse to limit maximum duty cycle to 90%, and a reset pulse to the internal circuitry.

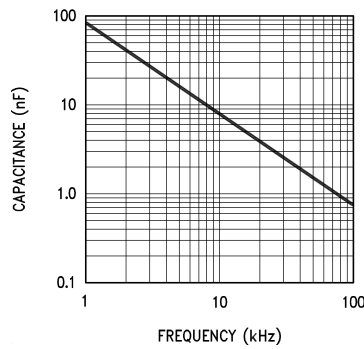

Figure 14. Value of Timing Capacitor vs Oscillator Frequency

OUTPUT TRANSISTOR

The output transistor is capable of delivering up to 750 mA with a saturation voltage of less than 0.9V. (see *Collector Saturation Voltage* and *Emitter Saturation Voltage* curves).

The emitter must not be pulled more than 1V below ground (this limit is 0.6V for $T_J \geq 100^\circ\text{C}$). Because of this limit, an external transistor must be used to develop negative output voltages (see the [Inverting Regulator Typical Application](#)). Other configurations may need protection against violation of this limit (see the [Emitter Output](#) section of the [Applications Information](#)).

CURRENT LIMIT

The LM2578A's current limit may be referenced to either the ground or the V_{in} pins, and operates on a cycle-by-cycle basis.

The current limit section consists of two comparators: one with its non-inverting input referenced to a voltage 110 mV below V_{in} , the other with its inverting input referenced 110 mV above ground (see [FUNCTIONAL DIAGRAM](#)). The current limit is activated whenever the current limit terminal is pulled 110 mV away from either V_{in} or ground.

Applications Information

CURRENT LIMIT

As mentioned in the functional description, the current limit terminal may be referenced to either the V_{in} or the ground terminal. Resistor R3 converts the current to be sensed into a voltage for current limit detection.

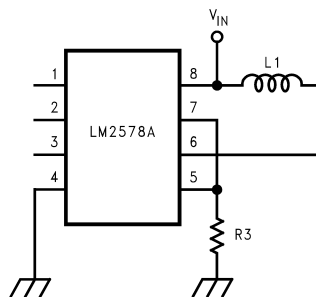

Figure 15. Current Limit, Ground Referred

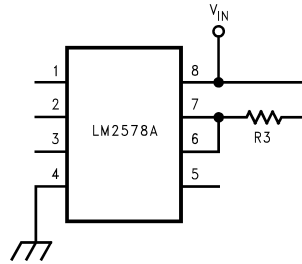

Figure 16. Current Limit, V_{in} Referred

CURRENT LIMIT TRANSIENT SUPPRESSION

When noise spikes and switching transients interfere with proper current limit operation, R1 and C1 act together as a low pass filter to control the current limit circuitry's response time.

Because the sense current of the current limit terminal varies according to where it is referenced, R1 should be less than 2 k Ω when referenced to ground, and less than 100 Ω when referenced to V_{in} .

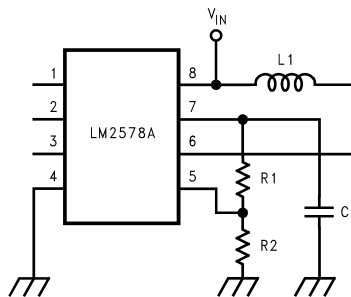

Figure 17. Current Limit Transient Suppressor, Ground Referred

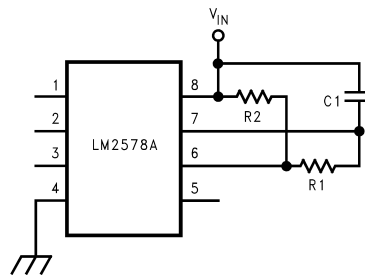

Figure 18. Current Limit Transient Suppressor, V_{in} Referred

C.L. SENSE VOLTAGE MULTIPLICATION

When a larger sense resistor value is desired, the voltage divider network, consisting of R1 and R2, may be used. This effectively multiplies the sense voltage by $(1 + R1/R2)$. Also, R1 can be replaced by a diode to increase current limit sense voltage to about 800 mV (diode $V_f + 110$ mV).

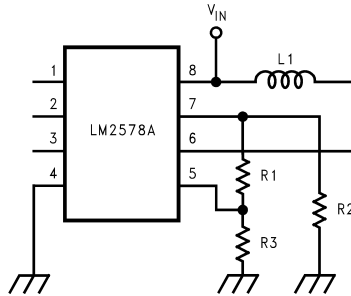

Figure 19. Current Limit Sense Voltage Multiplication, Ground Referred

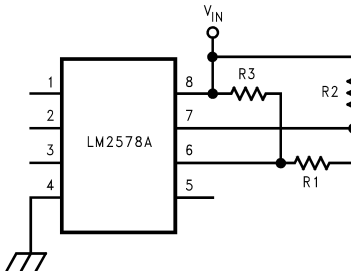

Figure 20. Current Limit Sense Voltage Multiplication, V_{in} Referred

UNDER-VOLTAGE LOCKOUT

Under-voltage lockout is accomplished with few external components. When V_{in} becomes lower than the zener breakdown voltage, the output transistor is turned off. This occurs because diode D1 will then become forward biased, allowing resistor R3 to sink a greater current from the non-inverting input than is sunk by the parallel combination of R1 and R2 at the inverting terminal. R3 should be one-fifth of the value of R1 and R2 in parallel.

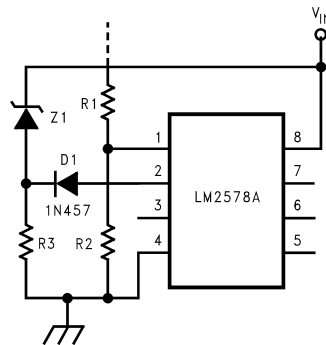

Figure 21. Under-Voltage Lockout

MAXIMUM DUTY CYCLE LIMITING

The maximum duty cycle can be externally limited by adjusting the charge to discharge ratio of the oscillator capacitor with a single external resistor. Typical values are 50 μA for the charge current, 450 μA for the discharge current, and a voltage swing from 200 mV to 750 mV. Therefore, R1 is selected for the desired charging and discharging slopes and C1 is readjusted to set the oscillator frequency.

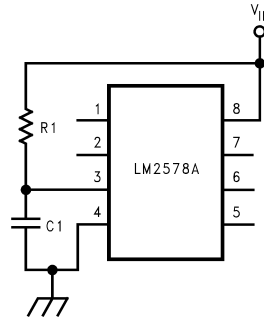

Figure 22. Maximum Duty Cycle Limiting

DUTY CYCLE ADJUSTMENT

When manual or mechanical selection of the output transistor's duty cycle is needed, the circuit shown below may be used. The output will turn on with the beginning of each oscillator cycle and turn off when the current sunk by R2 and R3 from the non-inverting terminal becomes greater than the current sunk from the inverting terminal.

With the resistor values as shown, R3 can be used to adjust the duty cycle from 0% to 90%.

When the sum of R2 and R3 is twice the value of R1, the duty cycle will be about 50%. C1 may be a large electrolytic capacitor to lower the oscillator frequency below 1 Hz.

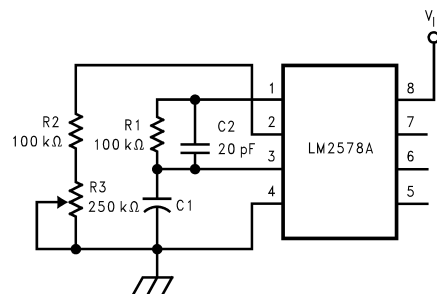

Figure 23. Duty Cycle Adjustment

REMOTE SHUTDOWN

The LM2578A may be remotely shutdown by sinking a greater current from the non-inverting input than from the inverting input. This may be accomplished by selecting resistor R3 to be approximately one-half the value of R1 and R2 in parallel.

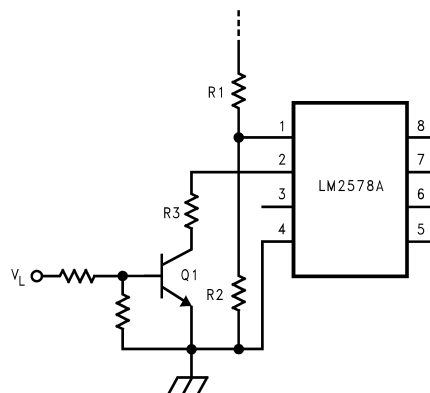

Figure 24. Shutdown Occurs when V_L is High

EMITTER OUTPUT

When the LM2578A output transistor is in the OFF state, if the Emitter output swings below the ground pin voltage, the output transistor will turn ON because its base is clamped near ground. The *Collector Current with Emitter Output Below Ground* curve shows the amount of Collector current drawn in this mode, vs temperature and Emitter voltage. When the Collector-Emitter voltage is high, this current will cause high power dissipation in the output transistor and should be avoided.

This situation can occur in the high-current high-voltage buck application if the Emitter output is used and the catch diode's forward voltage drop is greater than 0.6V. A fast-recovery diode can be added in series with the Emitter output to counter the forward voltage drop of the catch diode (see Figure 15). For better efficiency of a high output current buck regulator, an external PNP transistor should be used as shown in Figure 29.

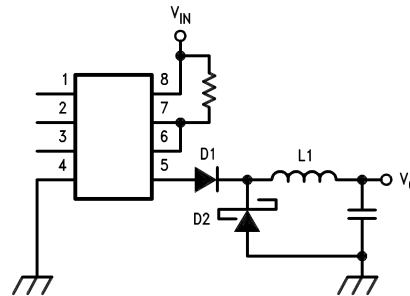

Figure 25. D1 Prevents Output Transistor from Improperly Turning ON due to D2's Forward Voltage

SYNCHRONIZING DEVICES

When several devices are to be operated at once, their oscillators may be synchronized by the application of an external signal. This drive signal should be a pulse waveform with a minimum pulse width of 2 μ s. and an amplitude from 1.5V to 2.0V. The signal source must be capable of 1.) driving capacitive loads and 2.) delivering up to 500 μ A for each LM2578A.

Capacitors C1 thru CN are to be selected for a 20% slower frequency than the synchronization frequency.

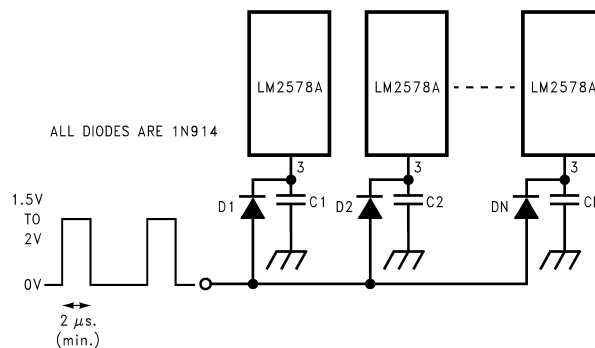

Figure 26. Synchronizing Devices

Typical Applications

The LM2578A may be operated in either the continuous or the discontinuous conduction mode. The following applications (except for the Buck-Boost Regulator) are designed for continuous conduction operation. That is, the inductor current is not allowed to fall to zero. This mode of operation has higher efficiency and lower EMI characteristics than the discontinuous mode.

BUCK REGULATOR

The buck configuration is used to step an input voltage down to a lower level. Transistor Q1 in [Figure 27](#) chops the input DC voltage into a squarewave. This squarewave is then converted back into a DC voltage of lower magnitude by the low pass filter consisting of L1 and C1. The duty cycle, D, of the squarewave relates the output voltage to the input voltage by the following equation:

$$V_{out} = D \times V_{in} = V_{in} \times (t_{on}) / (t_{on} + t_{off})$$

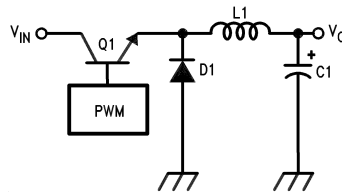

Figure 27. Basic Buck Regulator

[Figure 28](#) is a 15V to 5V buck regulator with an output current, I_o , of 350 mA. The circuit becomes discontinuous at 20% of $I_{o(max)}$, has 10 mV of output voltage ripple, an efficiency of 75%, a load regulation of 30 mV (70 mA to 350 mA) and a line regulation of 10 mV ($12 \leq V_{in} \leq 18V$).

Component values are selected as follows:

$$R1 = (V_o - 1) \times R2 \text{ where } R2 = 10 \text{ k}\Omega$$

$$R3 = V / I_{sw(max)}$$

$$R3 = 0.15\Omega$$

where:

V is the current limit sense voltage, 0.11V

$I_{sw(max)}$ is the maximum allowable current thru the output transistor.

L1 is the inductor and may be found from the inductance calculation chart ([Figure 29](#)) as follows:

Given $V_{in} = 15V$

$$V_o = 5V$$

$$I_{o(max)} = 350 \text{ mA}$$

$$f_{OSC} = 50 \text{ kHz}$$

Discontinuous at 20% of $I_{o(max)}$.

Note that since the circuit will become discontinuous at 20% of $I_{o(max)}$, the load current must not be allowed to fall below 70 mA.

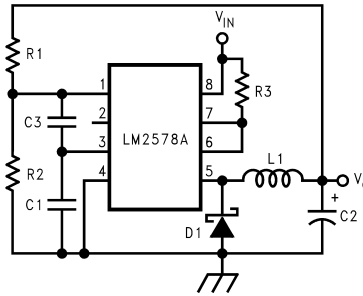

- $V_{in} = 15V$
- $V_o = 5V$
- $V_{ripple} = 10\text{ mV}$
- $I_o = 350\text{ mA}$
- $f_{osc} = 50\text{ kHz}$
- $R1 = 40\text{ k}\Omega$
- $R2 = 10\text{ k}\Omega$
- $R3 = 0.15\Omega$
- $C1 = 1820\text{ pF}$
- $C2 = 220\text{ }\mu\text{F}$
- $C3 = 20\text{ pF}$
- $L1 = 470\text{ }\mu\text{H}$
- $D1 = 1N5818$

Figure 28. Buck or Step-Down Regulator

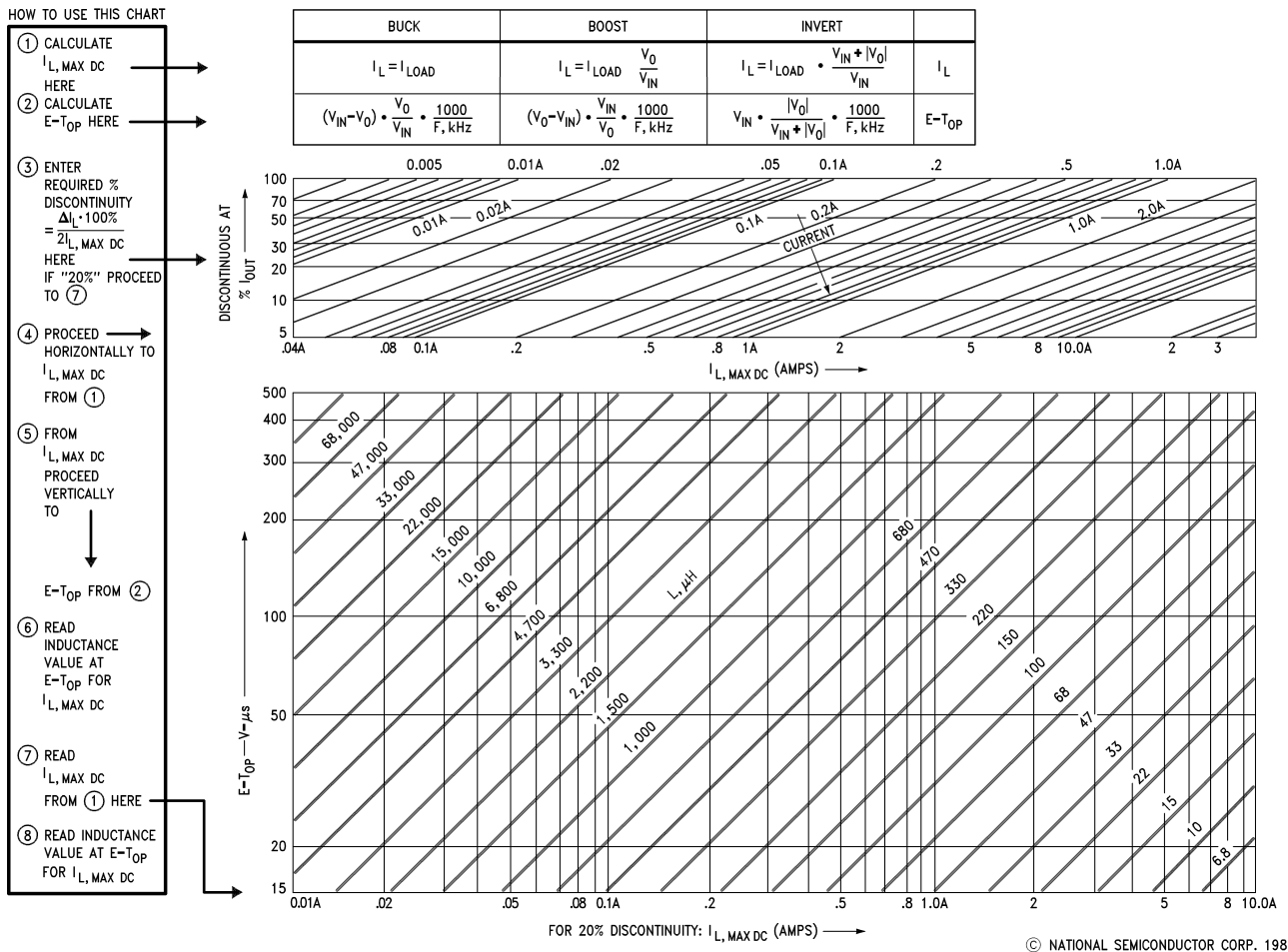

Figure 29. DC/DC Inductance Calculator

Step 1: Calculate the maximum DC current through the inductor, $I_{L(max)}$. The necessary equations are indicated at the top of the chart and show that $I_{L(max)} = I_{o(max)}$ for the buck configuration. Thus, $I_{L(max)} = 350$ mA.

Step 2: Calculate the inductor Volts-sec product, $E-T_{op}$, according to the equations given from the chart. For the Buck:

$$\begin{aligned} E-T_{op} &= (V_{in} - V_o) (V_o/V_{in}) (1000/f_{osc}) \\ &= (15 - 5) (5/15) (1000/50) \\ &= 66V-\mu s. \end{aligned}$$

with the oscillator frequency, f_{osc} , expressed in kHz.

Step 3: Using the graph with axis labeled “Discontinuous At % I_{OUT} ” and “ $I_{L(max, DC)}$ ” find the point where the desired maximum inductor current, $I_{L(max, DC)}$ intercepts the desired discontinuity percentage.

In this example, the point of interest is where the 0.35A line intersects with the 20% line. This is nearly the midpoint of the horizontal axis.

Step 4: This last step is merely the translation of the point found in Step 3 to the graph directly below it. This is accomplished by moving straight down the page to the point which intercepts the desired $E-T_{op}$. For this example, $E-T_{op}$ is 66V- μ s and the desired inductor value is 470 μ H. Since this example was for 20% discontinuity, the bottom chart could have been used directly, as noted in step 3 of the chart instructions.

For a full line of standard inductor values, contact Pulse Engineering (San Diego, Calif.) regarding their PE526XX series, or A. I. E. Magnetics (Nashville, Tenn.).

A more precise inductance value may be calculated for the Buck, Boost and Inverting Regulators as follows:

BUCK

$$L = V_o (V_{in} - V_o) / (\Delta I_L V_{in} f_{osc})$$

BOOST

$$L = V_{in} (V_o - V_{in}) / (\Delta I_L f_{osc} V_o)$$

INVERT

$$L = V_{in} |V_o| / [\Delta I_L (V_{in} + |V_o|) f_{osc}]$$

where ΔI_L is the current ripple through the inductor. ΔI_L is usually chosen based on the minimum load current expected of the circuit. For the buck regulator, since the inductor current I_L equals the load current I_o ,

$$\Delta I_L = 2 \cdot I_{o(min)}$$

$\Delta I_L = 140$ mA for this circuit. ΔI_L can also be interpreted as

$$\Delta I_L = 2 \cdot (\text{Discontinuity Factor}) \cdot I_L$$

where the Discontinuity Factor is the ratio of the minimum load current to the maximum load current. For this example, the Discontinuity Factor is 0.2.

The remainder of the components of [Figure 28](#) are chosen as follows:

C1 is the timing capacitor found in [Figure 14](#).

$$C2 \geq V_o (V_{in} - V_o) / (8f_{osc}^2 V_{in} V_{ripple} L1)$$

where V_{ripple} is the peak-to-peak output voltage ripple.

C3 is necessary for continuous operation and is generally in the 10 pF to 30 pF range.

D1 should be a Schottky type diode, such as the 1N5818 or 1N5819.

BUCK WITH BOOSTED OUTPUT CURRENT

For applications requiring a large output current, an external transistor may be used as shown in [Figure 30](#). This circuit steps a 15V supply down to 5V with 1.5A of output current. The output ripple is 50 mV, with an efficiency of 80%, a load regulation of 40 mV (150 mA to 1.5A), and a line regulation of 20 mV ($12V \leq V_{in} \leq 18V$).

Component values are selected as outlined for the buck regulator with a discontinuity factor of 10%, with the addition of R4 and R5:

$$R4 = 10V_{BE1}B_f/I_p$$

$$R5 = (V_{in} - V - V_{BE1} - V_{sat}) B_f/(I_{L(max, DC)} + I_{R4})$$

where:

V_{BE1} is the V_{BE} of transistor Q1.

V_{sat} is the saturation voltage of the LM2578A output transistor.

V is the current limit sense voltage.

B_f is the forced current gain of transistor Q1 ($B_f = 30$ for Figure 30).

$$I_{R4} = V_{BE1}/R4$$

$$I_p = I_{L(max, DC)} + 0.5\Delta I_L$$

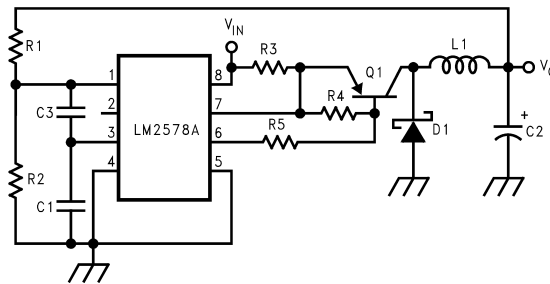

$$V_{in} = 15V$$

$$V_o = 5V$$

$$V_{ripple} = 50 \text{ mV}$$

$$I_o = 1.5A$$

$$f_{osc} = 50 \text{ kHz}$$

$$R1 = 40 \text{ k}\Omega$$

$$R2 = 10 \text{ k}\Omega$$

$$R3 = 0.05\Omega$$

$$R4 = 200\Omega$$

$$R5 = 330\Omega$$

$$C1 = 1820 \text{ pF}$$

$$C2 = 330 \mu\text{F}$$

$$C3 = 20 \text{ pF}$$

$$L1 = 220 \mu\text{H}$$

$$D1 = 1N5819$$

$$Q1 = D45$$

Figure 30. Buck Converter with Boosted Output Current

BOOST REGULATOR

The boost regulator converts a low input voltage into a higher output voltage. The basic configuration is shown in Figure 31. Energy is stored in the inductor while the transistor is on and then transferred with the input voltage to the output capacitor for filtering when the transistor is off. Thus,

$$V_o = V_{in} + V_{in}(t_{on}/t_{off}).$$

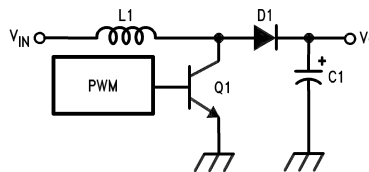
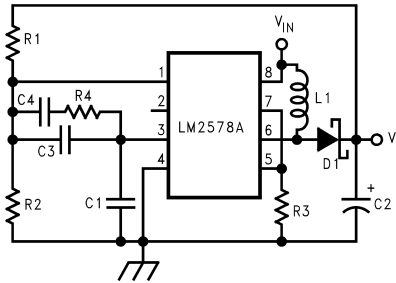

Figure 31. Basic Boost Regulator

The circuit of Figure 32 converts a 5V supply into a 15V supply with 150 mA of output current, a load regulation of 14 mV (30 mA to 140 mA), and a line regulation of 35 mV ($4.5V \leq V_{in} \leq 8.5V$).



$V_{in} = 5V$	$R4 = 200\text{ k}\Omega$
$V_o = 15V$	$C1 = 1820\text{ pF}$
$V_{ripple} = 10\text{ mV}$	$C2 = 470\text{ }\mu\text{F}$
$I_o = 140\text{ mA}$	$C3 = 20\text{ pF}$
$f_{osc} = 50\text{ kHz}$	$C4 = 0.0022\text{ }\mu\text{F}$
$R1 = 140\text{ k}\Omega$	$L1 = 330\text{ }\mu\text{H}$
$R2 = 10\text{ k}\Omega$	$D1 = 1N5818$
$R3 = 0.15\Omega$	

Figure 32. Boost or Step-Up Regulator

$R1 = (V_o - 1) R2$ where $R2 = 10\text{ k}\Omega$.

$R3 = V / (I_{L(max, DC)} + 0.5 \Delta I_L)$

where:

$\Delta I_L = 2(I_{LOAD(min)})(V_o/V_{in})$

ΔI_L is 200 mA in this example.

$R4$, $C3$ and $C4$ are necessary for continuous operation and are typically 220 k Ω , 20 pF, and 0.0022 μF respectively.

$C1$ is the timing capacitor found in [Figure 14](#).

$$C2 \geq I_o (V_o - V_{in}) / (f_{osc} V_o V_{ripple}).$$

$D1$ is a Schottky type diode such as a 1N5818 or 1N5819.

$L1$ is found as described in the [buck converter](#) section, using the inductance chart for [Figure 29](#) for the boost configuration and 20% discontinuity.

INVERTING REGULATOR

[Figure 33](#) shows the basic configuration for an inverting regulator. The input voltage is of a positive polarity, but the output is negative. The output may be less than, equal to, or greater in magnitude than the input. The relationship between the magnitude of the input voltage and the output voltage is $V_o = V_{in} \times (t_{on}/t_{off})$.

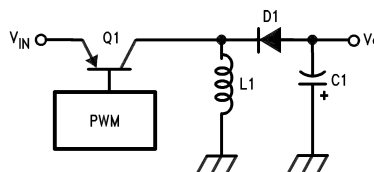

Figure 33. Basic Inverting Regulator

[Figure 34](#) shows an LM2578A configured as a 5V to -15V polarity inverter with an output current of 300 mA, a load regulation of 44 mV (60 mA to 300 mA) and a line regulation of 50 mV ($4.5V \leq V_{in} \leq 8.5V$).

$$R1 = (|V_o| + 1) R2 \text{ where } R2 = 10 \text{ k}\Omega.$$

$$R3 = V / (I_{L(\text{max, DC})} + 0.5 \Delta I_L).$$

$$R4 = 10V_{BE1} B_f / (I_{L(\text{max, DC})} + 0.5 \Delta I_L)$$

where:

V , V_{BE1} , V_{sat} , and B_f are defined in the [Buck Converter with Boosted Output Current](#) section.

$$\Delta I_L = 2(I_{LOAD(\text{min})})(V_{in} + |V_o|) / V_{IN}$$

$R5$ is defined in the [Buck Converter with Boosted Output Current](#) section.

$R6$ serves the same purpose as $R4$ in the Boost Regulator circuit and is typically 220 k Ω .

$C1$, $C3$ and $C4$ are defined in the [Boost Regulator](#) section.

$$C2 \geq I_o |V_o| / [f_{osc} (|V_o| + V_{in}) V_{ripple}]$$

$L1$ is found as outlined in the section on [buck converters](#), using the inductance chart of [Figure 29](#) for the invert configuration and 20% discontinuity.

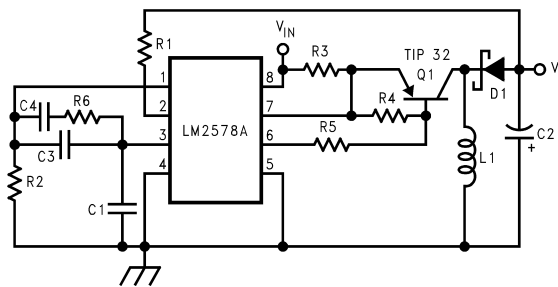

$$V_{in} = 5V$$

$$V_o = -15V$$

$$V_{ripple} = 5 \text{ mV}$$

$$I_o = 300 \text{ mA}$$

$$I_{min} = 60 \text{ mA}$$

$$f_{osc} = 50 \text{ kHz}$$

$$R1 = 160 \text{ k}\Omega$$

$$R2 = 10 \text{ k}\Omega$$

$$R3 = 0.01\Omega$$

$$R4 = 190\Omega$$

$$R5 = 82\Omega$$

$$R6 = 220 \text{ k}\Omega$$

$$C1 = 1820 \text{ pF}$$

$$C2 = 1000 \mu\text{F}$$

$$C3 = 20 \text{ pF}$$

$$C4 = 0.0022 \mu\text{F}$$

$$L1 = 150 \mu\text{H}$$

$$D1 = 1N5818$$

Figure 34. Inverting Regulator

BUCK-BOOST REGULATOR

The Buck-Boost Regulator, shown in [Figure 35](#), may step a voltage up or down, depending upon whether or not the desired output voltage is greater or less than the input voltage. In this case, the output voltage is 12V with an input voltage from 9V to 15V. The circuit exhibits an efficiency of 75%, with a load regulation of 60 mV (10 mA to 100 mA) and a line regulation of 52 mV.

$$R1 = (V_o - 1) R2 \text{ where } R2 = 10 \text{ k}\Omega$$

$$R3 = V / 0.75A$$

$R4$, $C1$, $C3$ and $C4$ are defined in the [Boost Regulator](#) section.

$D1$ and $D2$ are Schottky type diodes such as the 1N5818 or 1N5819.

$$C2 \geq \frac{(I_o / V_{ripple}) (V_o + 2V_d)}{[f_{osc} (V_{in} + V_o + 2V_d - V_{sat} - V_{sat1})]}$$

where:

V_d is the forward voltage drop of the diodes.

V_{sat} is the saturation voltage of the LM2578A output transistor.

V_{sat1} is the saturation voltage of transistor Q1.

$$L1 \geq (V_{in} - V_{sat} - V_{sat1}) (t_{on}/I_p) \quad (1)$$

where:

$$t_{on} = \frac{(1/f_{osc})(V_o + 2V_d)}{(V_o + V_{in} + 2V_d - V_{sat} - V_{sat1})}$$

$$I_p = \frac{2I_o(V_{in} + V_o + 2V_d - V_{sat} - V_{sat1})}{(V_{in} - V_{sat} - V_{sat1})}$$

RS-232 LINE DRIVER POWER SUPPLY

The power supply, shown in [Figure 36](#), operates from an input voltage as low as 4.2V (5V nominal), and delivers an output of $\pm 12V$ at ± 40 mA with better than 70% efficiency. The circuit provides a load regulation of ± 150 mV (from 10% to 100% of full load) and a line regulation of ± 10 mV. Other notable features include a cycle-by-cycle current limit and an output voltage ripple of less than 40 mVp-p.

A unique feature of this circuit is its use of feedback from both outputs. This dual feedback configuration results in a sharing of the output voltage regulation by each output so that neither side becomes unbalanced as in single feedback systems. In addition, since both sides are regulated, it is not necessary to use a linear regulator for output regulation.

The feedback resistors, R2 and R3, may be selected as follows by assuming a value of 10 k Ω for R1;

$$R2 = (V_o - 1V)/45.8 \mu A = 240 \text{ k}\Omega$$

$$R3 = (|V_o| + 1V)/54.2 \mu A = 240 \text{ k}\Omega$$

Actually, the currents used to program the values for the feedback resistors may vary from 40 μA to 60 μA , as long as their sum is equal to the 100 μA necessary to establish the 1V threshold across R1. Ideally, these currents should be equal (50 μA each) for optimal control. However, as was done here, they may be mismatched in order to use standard resistor values. This results in a slight mismatch of regulation between the two outputs.

The current limit resistor, R4, is selected by dividing the current limit threshold voltage by the maximum peak current level in the output switch. For our purposes $R4 = 110 \text{ mV}/750 \text{ mA} = 0.15\Omega$. A value of 0.1 Ω was used.

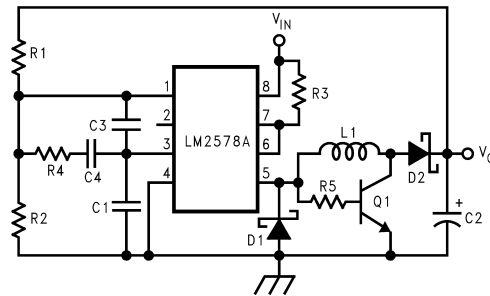

$$9V \leq V_{in} \leq 15V$$

$$V_o = 12V$$

$$I_o = 100 \text{ mA}$$

$$V_{\text{ripple}} = 50 \text{ mV}$$

$$f_{\text{osc}} = 50 \text{ kHz}$$

$$R1 = 110k$$

$$R2 = 10k$$

$$R3 = 0.15$$

$$R4 = 220k$$

$$R5 = 270$$

$$C1 = 1820 \text{ pF}$$

$$C2 = 220 \text{ }\mu\text{F}$$

$$C3 = 20 \text{ pF}$$

$$C4 = 0.0022 \text{ }\mu\text{F}$$

$$L1 = 220 \text{ }\mu\text{H}$$

$$D1, D2 = 1N5819$$

$$Q1 = D44$$

Figure 35. Buck-Boost Regulator

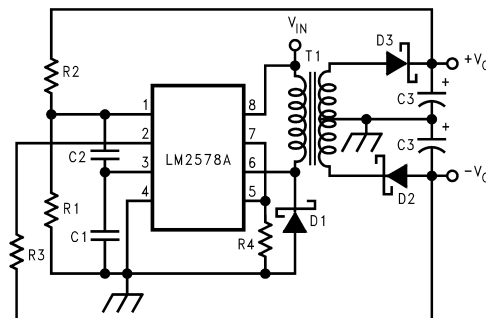

$$V_{in} = 5V$$

$$V_o \pm 12V$$

$$I_o = \pm 40 \text{ mA}$$

$$f_{\text{osc}} = 80 \text{ kHz}$$

$$R1 = 10 \text{ k}\Omega$$

$$R2 = 240 \text{ k}\Omega$$

$$R3 = 240 \text{ k}\Omega$$

$$R4 = 0.15\Omega$$

$$C1 = 820 \text{ pF}$$

$$C2 = 10 \text{ pF}$$

$$C3 = 220 \text{ }\mu\text{F}$$

$$D1, D2, D3 = 1N5819$$

$$T1 = PE-64287$$

Figure 36. RS-232 Line Driver Power Supply

Capacitor C1 sets the oscillator frequency and is selected from [Figure 14](#).

Capacitor C2 serves as a compensation capacitor for synchronous operation and a value of 10 to 50 pF should be sufficient for most applications.

A minimum value for an ideal output capacitor C3, could be calculated as $C = I_o \times t / \Delta V$ where I_o is the load current, t is the transistor on time (typically $0.4/f_{osc}$), and ΔV is the peak-to-peak output voltage ripple. A larger output capacitor than this theoretical value should be used since electrolytics have poor high frequency performance. Experience has shown that a value from 5 to 10 times the calculated value should be used.

For good efficiency, the diodes must have a low forward voltage drop and be fast switching. 1N5819 Schottky diodes work well.

Transformer selection should be picked for an output transistor “on” time of $0.4/f_{osc}$, and a primary inductance high enough to prevent the output transistor switch from ramping higher than the transistor's rating of 750 mA. Pulse Engineering (San Diego, Calif.) and Renco Electronics, Inc. (Deer Park, N.Y.) can provide further assistance in selecting the proper transformer for a specific application need. The transformer used in [Figure 36](#) was a Pulse Engineering PE-64287.

REVISION HISTORY

Changes from Revision D (April 2013) to Revision E	Page
<hr/> <ul style="list-style-type: none">• Changed layout of National Data Sheet to TI format	<hr/> 22

PACKAGING INFORMATION

Orderable Device	Status (1)	Package Type	Package Drawing	Pins	Package Qty	Eco Plan (2)	Lead/Ball Finish (6)	MSL Peak Temp (3)	Op Temp (°C)	Device Marking (4/5)	Samples
LM2578AM	NRND	SOIC	D	8	95	TBD	Call TI	Call TI	-40 to 125	2578 AM	
LM2578AM/NOPB	ACTIVE	SOIC	D	8	95	Green (RoHS & no Sb/Br)	SN CU SN	Level-1-260C-UNLIM	-40 to 125	2578 AM	Samples
LM2578AMX/NOPB	ACTIVE	SOIC	D	8	2500	Green (RoHS & no Sb/Br)	SN CU SN	Level-1-260C-UNLIM	-40 to 125	2578 AM	Samples
LM2578AN	LIFEBUY	PDIP	P	8	40	TBD	Call TI	Call TI	-40 to 125	LM2578AN	
LM2578AN/NOPB	ACTIVE	PDIP	P	8	40	Green (RoHS & no Sb/Br)	SN CU SN	Level-1-NA-UNLIM	-40 to 125	LM2578AN	Samples
LM3578AM	NRND	SOIC	D	8	95	TBD	Call TI	Call TI	0 to 125	3578 AM	
LM3578AM/NOPB	ACTIVE	SOIC	D	8	95	Green (RoHS & no Sb/Br)	SN CU SN	Level-1-260C-UNLIM	0 to 125	3578 AM	Samples
LM3578AMX	NRND	SOIC	D	8	2500	TBD	Call TI	Call TI	0 to 125	3578 AM	
LM3578AMX/NOPB	ACTIVE	SOIC	D	8	2500	Green (RoHS & no Sb/Br)	SN CU SN	Level-1-260C-UNLIM	0 to 125	3578 AM	Samples
LM3578AN	LIFEBUY	PDIP	P	8	40	TBD	Call TI	Call TI	0 to 125	LM3578AN	
LM3578AN/NOPB	ACTIVE	PDIP	P	8	40	Green (RoHS & no Sb/Br)	SN CU SN	Level-1-NA-UNLIM	0 to 125	LM3578AN	Samples

(1) The marketing status values are defined as follows:

ACTIVE: Product device recommended for new designs.

LIFEBUY: TI has announced that the device will be discontinued, and a lifetime-buy period is in effect.

NRND: Not recommended for new designs. Device is in production to support existing customers, but TI does not recommend using this part in a new design.

PREVIEW: Device has been announced but is not in production. Samples may or may not be available.

OBSOLETE: TI has discontinued the production of the device.

(2) Eco Plan - The planned eco-friendly classification: Pb-Free (RoHS), Pb-Free (RoHS Exempt), or Green (RoHS & no Sb/Br) - please check <http://www.ti.com/productcontent> for the latest availability information and additional product content details.

TBD: The Pb-Free/Green conversion plan has not been defined.

Pb-Free (RoHS): TI's terms "Lead-Free" or "Pb-Free" mean semiconductor products that are compatible with the current RoHS requirements for all 6 substances, including the requirement that lead not exceed 0.1% by weight in homogeneous materials. Where designed to be soldered at high temperatures, TI Pb-Free products are suitable for use in specified lead-free processes.

Pb-Free (RoHS Exempt): This component has a RoHS exemption for either 1) lead-based flip-chip solder bumps used between the die and package, or 2) lead-based die adhesive used between the die and leadframe. The component is otherwise considered Pb-Free (RoHS compatible) as defined above.

Green (RoHS & no Sb/Br): TI defines "Green" to mean Pb-Free (RoHS compatible), and free of Bromine (Br) and Antimony (Sb) based flame retardants (Br or Sb do not exceed 0.1% by weight in homogeneous material)

(3) MSL, Peak Temp. - The Moisture Sensitivity Level rating according to the JEDEC industry standard classifications, and peak solder temperature.

(4) There may be additional marking, which relates to the logo, the lot trace code information, or the environmental category on the device.

(5) Multiple Device Markings will be inside parentheses. Only one Device Marking contained in parentheses and separated by a "~" will appear on a device. If a line is indented then it is a continuation of the previous line and the two combined represent the entire Device Marking for that device.

(6) Lead/Ball Finish - Orderable Devices may have multiple material finish options. Finish options are separated by a vertical ruled line. Lead/Ball Finish values may wrap to two lines if the finish value exceeds the maximum column width.

Important Information and Disclaimer: The information provided on this page represents TI's knowledge and belief as of the date that it is provided. TI bases its knowledge and belief on information provided by third parties, and makes no representation or warranty as to the accuracy of such information. Efforts are underway to better integrate information from third parties. TI has taken and continues to take reasonable steps to provide representative and accurate information but may not have conducted destructive testing or chemical analysis on incoming materials and chemicals. TI and TI suppliers consider certain information to be proprietary, and thus CAS numbers and other limited information may not be available for release.

In no event shall TI's liability arising out of such information exceed the total purchase price of the TI part(s) at issue in this document sold by TI to Customer on an annual basis.

TAPE AND REEL INFORMATION

QUADRANT ASSIGNMENTS FOR PIN 1 ORIENTATION IN TAPE

*All dimensions are nominal

Device	Package Type	Package Drawing	Pins	SPQ	Reel Diameter (mm)	Reel Width W1 (mm)	A0 (mm)	B0 (mm)	K0 (mm)	P1 (mm)	W (mm)	Pin1 Quadrant
LM2578AMX/NOPB	SOIC	D	8	2500	330.0	12.4	6.5	5.4	2.0	8.0	12.0	Q1
LM3578AMX	SOIC	D	8	2500	330.0	12.4	6.5	5.4	2.0	8.0	12.0	Q1
LM3578AMX/NOPB	SOIC	D	8	2500	330.0	12.4	6.5	5.4	2.0	8.0	12.0	Q1

TAPE AND REEL BOX DIMENSIONS

*All dimensions are nominal

Device	Package Type	Package Drawing	Pins	SPQ	Length (mm)	Width (mm)	Height (mm)
LM2578AMX/NOPB	SOIC	D	8	2500	367.0	367.0	35.0
LM3578AMX	SOIC	D	8	2500	367.0	367.0	35.0
LM3578AMX/NOPB	SOIC	D	8	2500	367.0	367.0	35.0

P (R-PDIP-T8)

PLASTIC DUAL-IN-LINE PACKAGE



- NOTES:
- A. All linear dimensions are in inches (millimeters).
 - B. This drawing is subject to change without notice.
 - C. Falls within JEDEC MS-001 variation BA.

D (R-PDSO-G8)

PLASTIC SMALL OUTLINE



IMPORTANT NOTICE

Texas Instruments Incorporated and its subsidiaries (TI) reserve the right to make corrections, enhancements, improvements and other changes to its semiconductor products and services per JESD46, latest issue, and to discontinue any product or service per JESD48, latest issue. Buyers should obtain the latest relevant information before placing orders and should verify that such information is current and complete. All semiconductor products (also referred to herein as "components") are sold subject to TI's terms and conditions of sale supplied at the time of order acknowledgment.

TI warrants performance of its components to the specifications applicable at the time of sale, in accordance with the warranty in TI's terms and conditions of sale of semiconductor products. Testing and other quality control techniques are used to the extent TI deems necessary to support this warranty. Except where mandated by applicable law, testing of all parameters of each component is not necessarily performed.

TI assumes no liability for applications assistance or the design of Buyers' products. Buyers are responsible for their products and applications using TI components. To minimize the risks associated with Buyers' products and applications, Buyers should provide adequate design and operating safeguards.

TI does not warrant or represent that any license, either express or implied, is granted under any patent right, copyright, mask work right, or other intellectual property right relating to any combination, machine, or process in which TI components or services are used. Information published by TI regarding third-party products or services does not constitute a license to use such products or services or a warranty or endorsement thereof. Use of such information may require a license from a third party under the patents or other intellectual property of the third party, or a license from TI under the patents or other intellectual property of TI.

Reproduction of significant portions of TI information in TI data books or data sheets is permissible only if reproduction is without alteration and is accompanied by all associated warranties, conditions, limitations, and notices. TI is not responsible or liable for such altered documentation. Information of third parties may be subject to additional restrictions.

Resale of TI components or services with statements different from or beyond the parameters stated by TI for that component or service voids all express and any implied warranties for the associated TI component or service and is an unfair and deceptive business practice. TI is not responsible or liable for any such statements.

Buyer acknowledges and agrees that it is solely responsible for compliance with all legal, regulatory and safety-related requirements concerning its products, and any use of TI components in its applications, notwithstanding any applications-related information or support that may be provided by TI. Buyer represents and agrees that it has all the necessary expertise to create and implement safeguards which anticipate dangerous consequences of failures, monitor failures and their consequences, lessen the likelihood of failures that might cause harm and take appropriate remedial actions. Buyer will fully indemnify TI and its representatives against any damages arising out of the use of any TI components in safety-critical applications.

In some cases, TI components may be promoted specifically to facilitate safety-related applications. With such components, TI's goal is to help enable customers to design and create their own end-product solutions that meet applicable functional safety standards and requirements. Nonetheless, such components are subject to these terms.

No TI components are authorized for use in FDA Class III (or similar life-critical medical equipment) unless authorized officers of the parties have executed a special agreement specifically governing such use.

Only those TI components which TI has specifically designated as military grade or "enhanced plastic" are designed and intended for use in military/aerospace applications or environments. Buyer acknowledges and agrees that any military or aerospace use of TI components which have **not** been so designated is solely at the Buyer's risk, and that Buyer is solely responsible for compliance with all legal and regulatory requirements in connection with such use.

TI has specifically designated certain components as meeting ISO/TS16949 requirements, mainly for automotive use. In any case of use of non-designated products, TI will not be responsible for any failure to meet ISO/TS16949.

Products

Audio	www.ti.com/audio
Amplifiers	amplifier.ti.com
Data Converters	dataconverter.ti.com
DLP® Products	www.dlp.com
DSP	dsp.ti.com
Clocks and Timers	www.ti.com/clocks
Interface	interface.ti.com
Logic	logic.ti.com
Power Mgmt	power.ti.com
Microcontrollers	microcontroller.ti.com
RFID	www.ti-rfid.com
OMAP Applications Processors	www.ti.com/omap
Wireless Connectivity	www.ti.com/wirelessconnectivity

Applications

Automotive and Transportation	www.ti.com/automotive
Communications and Telecom	www.ti.com/communications
Computers and Peripherals	www.ti.com/computers
Consumer Electronics	www.ti.com/consumer-apps
Energy and Lighting	www.ti.com/energy
Industrial	www.ti.com/industrial
Medical	www.ti.com/medical
Security	www.ti.com/security
Space, Avionics and Defense	www.ti.com/space-avionics-defense
Video and Imaging	www.ti.com/video

TI E2E Community

e2e.ti.com

Mouser Electronics

Authorized Distributor

Click to View Pricing, Inventory, Delivery & Lifecycle Information:

Texas Instruments:

[LM2578AM](#) [LM2578AM/NOPB](#) [LM2578AMX/NOPB](#) [LM2578AN](#) [LM2578AN/NOPB](#) [LM3578AM](#) [LM3578AM/NOPB](#)
[LM3578AMX](#) [LM3578AMX/NOPB](#) [LM3578AN](#) [LM3578AN/NOPB](#)